

**Section II: Site Operator's Responsibilities for the
Operation of the Met One Instruments
Beta Attenuation Monitor (BAM 1020)**

**Quality Assurance Plan/ Standard Operating Procedure
(QAP/SOP)**

**Met One Instruments
BAM 1020
Continuous Ambient Particulate Matter PM_{2.5} Monitor**

Approval Sign Off-Sheet

I certify that I have read and approve of the contents of this revision of the Metone BAM 1020 Operator's QAP/SOP with an effective date of 11/1/2011.

Eddie Todd, Regional Coordinator/Lead: Eddie Todd 10/18/2011

Tony Sabetti, Regional Coordinator/Lead: Tony Sabetti 10/21/2011

Jim McGaughey, Central Office Lead: Jim McGaughey 10/17/11

Frank Stellitano, ECB Supervisor: Frank R. Stellitano 10/26/2011

Joette Steger, PPB Supervisor: Joette Steger 10/25/2011

Donnie Redmond, Ambient Monitoring Section Chief: Donnie Redmond 10/26/11

RECEIVED

OCT 21 2011

DAQ WIRO

Table of Contents

2.37.2 BAM 1020 QAP/SOP for Site Operators

2.37.2.1 Description of BAM 1020

2.37.2.2 Site Operator Responsibilities

2.37.2.2.1 Site Visits

2.37.2.2.2 Flow Rate Check

2.37.2.2.3 Flow Rate Audits

2.37.2.2.4 Leak Checks

2.37.2.2.5 Nozzle and Vane Cleaning

2.37.2.2.6 Filter Tape Installation

2.37.2.2.7 Zero Background Test

2.37.2.3 Site Documentation and Data Handling

2.37.2.3.1 Downloading Raw Data

2.37.2.3.2 Set-up

2.37.2.3.3 Description of Downloaded File Information

2.37.2.3.4 File Management

2.37.2.3.5 BAM Monthly Data Validation

2.37.2.4 BAM Preventive Maintenance

2.37.2.4.1 Inlet Cleaning

2.37.2.4.2 Shelter Temperature Control

2.37.2.4.3 Nozzle and Vane Cleaning

2.37.2.4.4 Capstan and Pinch Roller Cleaning

Appendix A Diagram of BAM 1020 System

Appendix B Summary of Scheduled Activities

Appendix C Example of E:LOG Forms

Appendix D Annual Background Test Procedure

Note: The following is a list of significant changes from Revision 0:

- 1) Review of data after each download (see Section 2.37.2.2);
- 2) Visually inspect filter tape for poor sample collection (see Section 2.37.2.2.1);
- 3) Addition of "Qtot" value to e:log (see Section 2.37.2.2.1);
- 4) Perform Flow/Leak check every 30 days \pm 5 days (see Sections 2.37.2.2.2 and 2.37.2.2.4);
- 5) Flow rate acceptance criteria changed from 16.67 ± 1 LPM to 16.67 ± 0.67 LPM (see Section 2.37.2.2.2)
- 6) Data invalidation due to failed leak check (see Section 2.37.2.2.4);
- 7) Monthly data validation guidance (see Section 2.37.2.3.5 and Table 1); and
- 8) Annual background test procedure (see Section 2.37.2.2.7 and Appendix D)

2.37.2 BAM 1020 QAP/SOP for Site Operators

The following document describes the operation and all operator responsibilities for the Met One Instruments, Beta Attenuation Monitor (BAM) 1020 used for the continuous measurement of ambient air concentrations of particulate matter with an aerodynamic diameter equal to or less than 2.5 micrometers.

2.37.2.1 Description of the BAM 1020

The BAM 1020 automatically measures and records airborne particulate matter (PM) concentration levels in $\mu\text{g}/\text{m}^3$ at local conditions of temperature and atmospheric pressure using the principle of beta ray attenuation. A small, Carbon 14 (^{14}C) source emits a constant source of high-energy electrons known as beta particles, which are detected and counted by a sensitive scintillation detector. An external pump pulls a measured amount of PM laden air through a glass fiber filter tape. Once per hour, after the filter tape has collected some amount of ambient PM, it is automatically placed between the source and the detector thereby causing an attenuation of the beta particle signal. The degree of attenuation of the beta particles is used to determine the mass concentration of PM in the ambient air. The monitor measures a background or "zero" signal at a predetermined spot on the filter tape, which has not been exposed to the ambient air. The monitor then pulls ambient air through the same spot on the filter at a rate of 16.67 liters per minute (LPM) for a specified period of time. (See appendix A for a diagram of the BAM 1020 system.)

The BAM is configured to operate on 1-hour cycles. During this one hour cycle, the unit makes two 8-minute beta measurements (one for the background or blank and one for the sample) and collects one 42-minute sample for a combined total of 58 minutes. The remaining 2-minutes of each hour are used for filter tape and nozzle movements. At a preset clock time (time 00 for this discussion), the BAM advances the filter tape forward one "window" (next unused spot) where the tape is positioned between beta source and the detector. The BAM begins counting beta particles for exactly 8-minutes. At the end of minute 08, the BAM stops counting the clean spot and advances the tape exactly four windows forward, positioning that same spot under the sampling nozzle. The nozzle is

lowered into position, the pump turns on and the sample is collected for exactly 42-minutes at a design flow rate of 16.67 LPM. At the end of minute 50, the pump stops, the nozzle is raised and the tape moves backwards exactly four windows. The spot that was just loaded with PM is now positioned between the beta source and the detector. The BAM begins counting beta particles for exactly 8-minutes. At the end of minute 58, the BAM stops counting and calculates the PM concentration. At the end of minute 60, the BAM records the concentration to memory, provides a corresponding analog output signal to the data logger and advances the filter tape to a fresh spot and the cycle begins over at minute 00.

During each 42-minute sampling period, the BAM automatically performs quality control checks of system performance. A span check is performed by automatically inserting a calibrated membrane between the source and the detector. The response is compared to the factory determined value. The BAM also checks for instrument drift caused by varying external parameters such as temperature, barometric pressure and relative humidity. If either the calibration or the drift is found to be outside of specifications, the BAM flags the data that was generated for that hour.

The small, ^{14}C element is a sealed source with a sufficiently low activity as to be below the Federal "Exempt Concentration Limit" and poses no health hazard. The source has a very long half-life (5000 + years) and should never need replacing. However, under no circumstances should anyone but factory technicians attempt to remove or access the beta source.

The sample inlet system is equipped with a PM10 head which is used to separate out PM that is equal to or larger than 10 micrometers in diameter and a PM2.5 very sharp cut cyclone (VSCC) which is used to further separate out PM larger than 2.5 micrometers in diameter. **The BAM 1020 received the designation as a Federal Equivalent Method (FEM) for measuring PM2.5 in the ambient air from the EPA on March 12, 2008. To maintain this status, the instrument must be operated as detailed in the instruction manual and as outlined in the procedures provided in this QAP/SOP.**

The "Main Menu" and keyboard are shown in Figure 1 below, followed by a description of the keyboard functions.

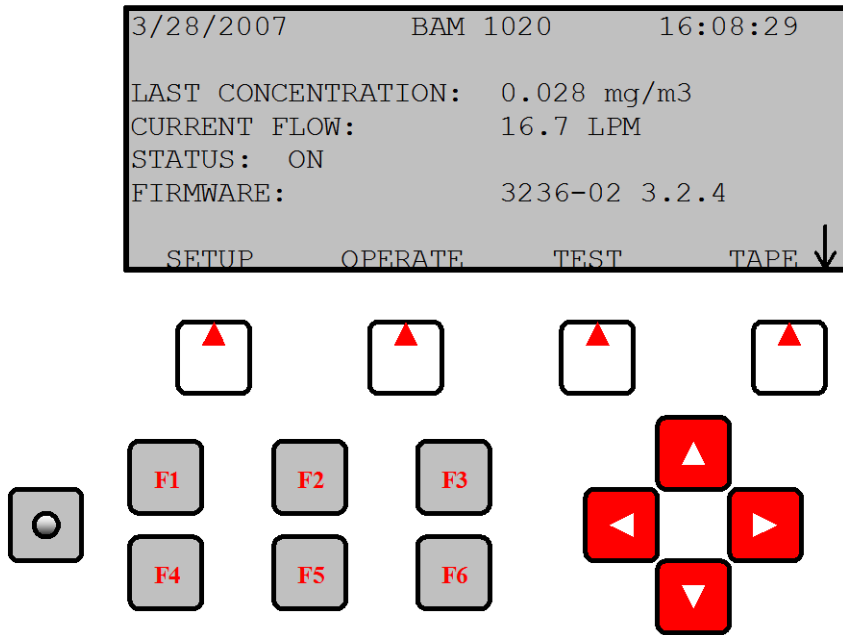

Figure 1. The BAM-1020 Main Menu and Keyboard

Soft Keys:

Directly beneath the display are four white buttons called “soft-keys” or “hot-keys”. These are dynamic keys whose function changes in response to a menu option displayed directly above each key on the bottom row of the display. Whatever menu option is displayed above one of these keys is the function which that key will perform in that particular menu. These are used throughout the entire menu system for a wide variety of functions. For example, changes/updates made within a menu are usually not saved unless a SAVE soft-key is pressed. EXIT is also another common soft-key function.

Arrow (Cursor) Keys:

The four red arrow keys are used to scroll up, down, left, and right to navigate in the menu system, and to select items or change fields on the screen. The arrow keys are also often used to change parameters or increment/decrement values in the menu system.

Contrast Key:

The key with a circular symbol on it is for adjusting the light/dark contrast on the LCD display. Press and hold the key until the desired contrast is achieved. It is possible to over-adjust the contrast and make the entire display completely blank or completely dark, so be careful to set it to a visible level or it may appear that the unit is not operating.

Function Keys F1 to F6:

The function keys serve as shortcuts to commonly used menu screens, and can be safely pressed at almost any time without interrupting the sample cycle. The **F** keys are only functional from the main menu screen or for entering passwords. The factory default

password is F1, F2, F3, F4.

F1 Current: This key is a shortcut to the OPERATE > INST screen, used to display the instantaneous data values that are being measured by the BAM-1020. The F1 key can be used without interrupting a sample cycle.

F2 Average: This key is a shortcut to the OPERATE > AVERAGE screen, used to display the latest average of the data recorded by the BAM-1020. The F2 key can be used without interrupting a sample cycle.

F3 Error Recall: This key allows the user to view the errors logged by the BAM-1020. The errors are sorted by date. The last 12 days which contain error records are available, and up to the last 100 errors can be viewed. The F3 key can be used without interrupting a sample cycle.

F4 Data Recall: This key allows the user to view the data stored in the BAM-1020, including concentrations, flow, and all six external channels. The data is sorted by date, and the user can scroll through the data hour-by-hour using the soft-keys. Only the last 12 days which contain data records are available in this menu. The F4 key can be used without interrupting a sample cycle.

F5 Transfer Module: This key is used to copy the memory contents to an optional transfer storage module to retrieve the digital data without a computer. This function is rarely used. Met One recommends downloading the data with a laptop, computer or modem connection.

F6 (Blank): This key is not assigned a data function.

2.37.2.2 Site Operator Responsibilities

The site operators will have the responsibility for the daily operation of the BAM. Site operators are assigned by the regional field offices. All activities performed during each site visit must be accurately and completely documented on the electronic field data e:log forms and in the site logbook. Any BAM malfunctions, problems or questionable operations should be reported immediately to the regional chemist, the Electronics and Calibration Branch (ECB) and the Central Office (CO) BAM lead. All site documentation and downloaded data files are to be maintained at the Regional Office (RO) for review and storage and placed on the P:drive at least monthly. The following is a list of the tasks, task frequency and responsibilities for all BAM site operators. Each topic is discussed in detail in subsequent sections of this document. (See Appendix B for Summary Table.)

- 1) **Site visits and quality assurance checks for the BAM:** Conducted at a minimum of once every 14-days (See Section 2.37.2.2.1);
- 2) **Flow rate checks:** Performed at least once every 30 days (See Section 2.37.2.2.2);
- 3) **Flow Rate Audits:** Performed once per quarter during the second month of each quarter (See Section 2.37.2.2.3);
- 4) **Leak checks:** Performed at least once every 30 days in conjunction with the flow check and/or filter tape change. (See Section 2.37.2.2.4);

- 5) **Nozzle and Vane Cleaning:** Performed as needed, but at least once every 30 days in conjunction with the flow check and/or filter tape change. (See Section 2.37.2.2.5);
- 6) **Filter Tape Installation:** Replace the sample filter tape when needed. If operating properly, each roll of filter tape should last for approximately two (2) months. (See Section 2.37.2.2.6);
- 7) **Site Documentation:** Download BAM data on site, minimum of every 14 days (site visits), store data and elogs monthly to the P:drive. (See Section 2.37.2.3);
- 8) **BAM Preventative Maintenance** (see Section 2.37.2.4):
 - a. Clean cut-point inlets at least once every 30 days;
 - b. Inspect/replace "O" rings associated with cut-point inlets;
 - c. Inspect filter tape during each visit checking for holes in the used portion of the tape as well as the sharpness of the collected PM spots;
 - d. Clean the capstan and pinch rollers as needed, but at least once every 30 days;
 - e. Clean the nozzle and vane as needed, but at least once every 30 days;
 - f. Inspect shelter heating/cooling system to ensure enclosure temperature does not vary by more than ± 3 °C over any one-hour period over the range of 20-30 °C, inspect/clean exhaust fans/filter; and
 - g. Ensure that the "Smart Heater" is operational by **quickly** touching the heater or adjacent sample tube. It should, at a minimum, be warm to the touch.
- 9) **Review of Data:** Poll the site/monitor on a daily basis. Review the hourly concentration data for any anomalies and/or operational instrument malfunction flags (such as 915 and/or 995). At this time, two (2) channels are available for review: 1) PM concentration and 2) shelter temperature. Review the downloaded data after each download (See Section 2.37.2.3).
- 10) **Annual "Zero Background" Test:** Perform with assistance from the ECB/CO (See Section 2.37.2.2.7 and Appendix D).

2.37.2.2.1 Site Visits

The site operator will, at a minimum, visit the site at least once every two weeks (approximately every 14 days) to inspect the BAM operations and perform any scheduled activities as listed above.

General Observations:

- 1) Check the instrument status: (sampling, counting, error etc.)
- 2) Check the "Smart Heater": Should be at least warm to the touch. CAUTION: HOT SURFACE;
- 3) Check operation of the shelter heating/cooling; and
- 4) Visually inspect the filter tape immediately to the left of the nozzle (See Figure 4). If the edges of previously sampled filter spot circles are not sharp or the filter tape displays puncture holes, the nozzle/vane requires cleaning. If necessary, unwind a portion of the used filter tape (left side roll) to determine date/time that such conditions began and document on the elog. Either condition would be

indicative of poor sample collection and possibly a failing leak check. The affected data should be identified as a note in the AQS monthly data summary and either flagged in AQS by the CO or voided with a Null Code. Consult the CO BAM lead in this circumstance.

Selected BAM operational parameters (read from the instrument screen) are to be recorded on the BAM e-log "Site_Visit" form (See Appendix C). This form is the record of the operating conditions observed at the time of the site visit and serves as the quality assurance documentation of the site operations. The items to be entered on the form are read from the available BAM menu screens. The "As Found" values" are to be entered before any tasks or maintenance is done on the BAM. Once the "As Found" values are recorded on the form, the operator can download the data stored on the BAM unit to a PC (or laptop), and/or complete other scheduled/unscheduled tasks.

OPERATIONAL PARAMETERS TO BE RECORDED ON THE E:LOG

Note: All of the key strokes that are discussed below can be performed without interrupting the operation of the instrument.

From the Main Menu record...

1. **Clock Time** (Must agree with data logger to within ± 1 minute, EST). If not, reset the BAM time by pressing the <Set-Up> soft key from the "Main Menu" and then press the <Clock> key to enter the Clock Menu and make any updates necessary using the red arrow keys;
2. **Date:** Date of site visit. Must agree with current date. If not use the <Set-Up> and <Date> keys;
3. **Status:** Instrument status as indicated (sampling, counting, error etc.);

Next, from the "Main Menu" press the red <Down Arrow> key to reach the "Flow Statistics" screen and record...

4. **Flow Rate:** LPM;
5. **Average Flow:** LPM;
6. **Flow CV:** %;

From the "Flow Statistics" screen press the red <Down Arrow> key again and record...

7. **AT:** ambient air temperature, °C; must agree within ± 2 °C of NIST reference;
8. **BP:** ambient barometric pressure, mmHg; must agree within ± 10 mm Hg of NIST reference;

Press <EXIT> soft key twice to return to "Main Menu", then press <Operate> soft key and <Normal> soft key to enter "Normal Mode" screen and record...

9. **Last C:** last concentration, ug/m³;
10. **Last M:** last hour's calibration value ($\pm 4\%$ of specific factory determined ABS value assigned to each instrument, i.e., 0.823 mg/cm² for Millbrook);
11. **RH:** relative humidity of air stream below filter, should be nominally 35% or less;

Press <Exit> once to reach "Operational Mode" screen and press <Inst> soft key and record...

12. **Qtot:** total volume sampled in m³ for the last hour and must be 0.700 ± 0.028 , or, said differently, in the range of 0.672 to 0.728. (Qtot is 16.67 LPM x 42 minutes/1000).

Press <Exit> to return to the "Main Menu" screen. Press the <F3>key to view the errors log and record...

13. **Errors:** In the notes section of the e:log, record any error message since the last site visit. The date/time of an error message will be helpful in applying a Null Code(s) during the AQS monthly data summary review. Press <exit> to return to "Main Menu".
14. **Shelter T.:** °C (this is the interior temperature of the outdoor shelter and should not vary by more than ± 3 °C over the duration of each 1-hour sampling period. Should be maintained in the range of 20-30 °C; value obtained from e:das/site computer);
15. **Smart Heater:** At least warm to the touch, "Yes" or "No";
16. **Shelter Temperature Control:** Heater/AC working, "Yes" or "No"; and
17. **Filter Tape:** Filter Tape Changed, "Yes" or "No";

2.37.2.2.2 Flow Rate Check.

The site operator will perform a precision flow rate check, at a minimum, once every 30 days (± 5 days to accommodate weekends/holidays) to verify the flow rate of the BAM unit. (This may change to once every 14-days if the BAM is used as the primary reporting instrument for the NAAQS at sometime in the future). A "check" is defined as a test of the mass flow controller (MFC) using an external standard. The flow rate check is done using an orifice type flow transfer standard (FTS) that is accurate to $\pm 2\%$ relative to a NIST standard. (Only one FTS is necessary for the measurement of the 16.7 LPM total flow). **The FTS device, as well as the manometers, temperature/barometric pressure readout devices used for the quarterly audit cannot be used for the flow rate check.** The data logger's BAM concentration channel should be marked "down" during the flow rate check using the site computer. All flow rate check values and information are to be entered at the appropriate places on the "Flow_Leak" sheet of the e:log (See Appendix C).

The flow rate check is performed as follows:

1. Start the flow check by marking the BAM concentration channel as "DOWN" on the 8816/8832 data logger;
2. Remove the PM-10 inlet from the sampling system. Install the FTS device on the VSCC cyclone. The FTS selected must be one that was calibrated to read in the range of 16.7 liters per minute ("high flow") and be within the FTS certification window;

3. From the main screen, press the <TEST> soft key on the keypad to enter the TEST MODE screen. This terminates the current sampling sequence. Using the red <Arrow> keys, move the high lighter to FLOW and press <SELECT>. The nozzle should be in the down position with the pump running;
4. Using the <NEXT> soft key, move the high lighter so that it is positioned at FLOW 3 (16.7). The value under the column header "BAM" is the current reading. Record the **current BAM flow** reading on the e:log;
5. Take a reading from the manometer and record the value as **manometer ΔP** on the Flow_Leak page of the e:log. (Note: Do not use a manometer that is indicating a "Low Battery" or outside of the certification window.);
6. Using hand held or other independent NIST traceable devices that are within the certification window, measure the **ambient temperature and pressure** and record the values;
7. Remove the FTS and reinstall the PM-10 inlet;
8. Press the "EXIT" soft key to return to the previous menu;
9. Using a calculator and the formula furnished with each flow transfer standard, calculate the actual flow rate. Care must be taken to use the slope and intercept values provided with the device that reflect the use of ambient pressure in units of atmospheres. The e-log workbook will automatically perform this calculation after the measure values (proper units) are entered. The formula for the calculation of actual (or true) flow is given below along with notes on applying the input values.

$$Q_a = \left[M \times \sqrt{\frac{\Delta P \times T}{P}} \right] + b$$

Q_a = Actual Flow, LPM

b = orifice calibration intercept

T = ambient temperature, °Kelvin

M = slope value of the orifice calibration

P = ambient barometric pressure

ΔP = manometer reading inches of water

[Note: Ambient temperature and ambient pressure values must be in the correct units before applying to the above equation. The ambient temperature must be recorded on the e-log in degrees C. The e-log automatically converts the degrees C to degrees Kelvin for use in the formula. The slope and intercept values provided for each FTS are based on pressure units of either "mm Hg" or "atmospheres". **To remove any confusion, the slope and intercept values to be used must be those associated with pressure in atmospheres.** (To convert mmHg to atmospheres divide by 760.) Also, the ambient pressure must be in units of atmospheres. After entering the slope and intercept values, the ambient pressure/temperature and the manometer ΔP , the e-log will automatically calculate all values.]

The specification for acceptable flow is **16.67 LPM \pm 0.67** [which is \pm 4% (as specified by the EPA) of the design flow rate of 16.67 and falls in the range of 16.00 to 17.34 LPM]. After these tasks are completed, mark the BAM data logger channels "Up".

Pass/Fail Criteria

- 1) If the actual (FTS calculated) flow **is** within specification and the BAM reading is also within specification, the flow check passes. No further action is required.
- 2) If the actual (FTS calculated) flow **is** within specification, but the BAM reading is not, the flow check passes. Contact the ECB.
- 3) If the actual (FTS calculated) flow is **not** within specification, the flow check fails. The mass flow controller must be recalibrated by the ECB. Contact the regional chemist and the ECB. To determine the actual date/time that the flow rate fell outside of the control limits, review the downloaded data file looking specifically at the historical "Qtot" column. "Qtot" is the total sample volume for each hour. The target value for "Qtot" is 0.700 m³. Values falling outside of the range of 0.672 to 0.728 indicate invalid concentration data. All concentration values back to the data/time when the "Qtot" was within acceptable limits will be invalid.

If the flow check result is outside of the specification, contact the Regional Chemist or the CO BAM lead immediately. The Regional Chemist/CO BAM lead will review the calculations and procedure and if necessary have the ECB perform an independent audit to verify the flow rates. If the ECB audit result agrees that the flow rate is outside of the specification limits, the BAM flow controller must be recalibrated by the ECB. Record all results on the e:log.

2.37.2.2.3 Flow Rate Audits

Flow Audits are to be performed during the second month of each quarter. **Audits are to be performed by an individual other than the "normal" operator. The FTS device, as well as the manometer, temperature/barometric pressure readout devices used for the quarterly audit cannot be the ones used for the flow rate checks.** Except for the equipment used, the procedure for performing the "Independent Flow Audit" is the same as described in Section 2.37.2.2.2 of this QA document under "Flow Rate Check".

Record all results on the e:log.

2.37.2.2.4 Leak Checks

"As Found" leak checks must be performed at least once every 30 days (\pm 5 days) and whenever the filter tape is changed. **When the filter tape is changed, a leak check must be performed immediately before (AS FOUND) and immediately after (AS LEFT) the change.** Almost all air leaks in the BAM system occur at the nozzle where it contacts the filter tape. The BAM-1020 has no way of automatically detecting a leak at this

interface, because the airflow sensor is located downstream of the filter tape. A poor seal at this point lets an unknown amount of air enter the system from a location other than through the inlet. This will cause the calculation of the concentration to be incorrect.

Allowing a leak to persist may cause an unknown amount of data to be invalidated!

Record leak check results on the e:log. Perform the following steps to check for leaks:

Leak Check with Filter Tape In-Place

1. **Remove only the PM₁₀ head** from the inlet tube. Install a leak test valve onto the **inlet of the VSCC**. Turn the valve to the OFF position to prevent any air from entering the inlet tube.
2. From the MAIN menu, enter the TEST > TAPE menu; Select "FEED", use the red "up-down" arrow keys to select "1" and then press the "FWD" key to advance the tape one "window" to a fresh, unused spot. Exit back to the TEST menu.
3. From the TEST > PUMP menu, turn the pump on. The flow rate should drop below 1.0 LPM. If the leak flow value is 0.75 LPM or greater, then the nozzle and vane need cleaning, or there may be another small leak in the system. Refer to Section 2.37.2.2.5 for nozzle/vane cleaning procedure.
4. Resolve the leak and perform the check again. A properly functioning BAM with a clean nozzle and vane will usually have a leak value of about 0.5 LPM or less. **The acceptance criteria for the DAQ, is currently set at a flow of 0.75 LPM or less.**
5. Turn the pump off, remove the leak test valve, and re-install the inlet PM₁₀ head. If a flow rate greater than 0.75 LPM is observed, leaks can be further isolated using a soft rubber seal (supplied with the monitor) with a 1/4" hole in it, such as Metone Part No. 7440. Refer to the discussion below which details "Leak Check with Filter Tape Removed and Using Rubber Nozzle Seal"
6. If the leak check passes, "EXIT" to the MAIN menu and the BAM will start sampling at the top of the next hour.
7. If the "As Found" leak check fails, all data back to the last good leak check must be invalidated.

Leak Check with Filter Tape Removed and Using Rubber Nozzle Seal

The filter tape is removed and the rubber seal inserted with the hole centered under the nozzle. The seal allows the leak check to be performed as usual (from the VSCC through the entire system), but without any leakage through the filter tape. The leak value should drop to 0.2 LPM or less with this method. A leak can be further isolated by using the part of the seal without the hole. This allows a leak test to be performed only on the system below the filter tape junction. If the nozzle and vane are thoroughly clean, but a leak persists, inspect/replace the "O" rings in the VSCC and perform the test again. If the leak still persists, contact the ECB. The leak test, using the rubber seal is performed as follows:

1. From the "Main Menu", press the <TEST> soft key to enter the TEST MODE screen;
2. Using the red <ARROW> keys, scroll to PUMP and press the <SELECT> key;

3. If the pump is running, press the <PUMP OFF> key. If the nozzle is in the down position, press the <MOVE NOZZLE> key to move it to the up position;
4. Lift the "pinch" roller (See Figure 5) until the latch automatically locks it in the up position. Carefully slide the filter tape out of position. This may require unwinding a very small amount of filter tape from the roll to provide some slack in the tape without causing damage to the tape;
5. Insert the provided rubber nozzle seal (part # 7440) (with a ¼" hole) and center it under the nozzle. Make sure the surfaces of the rubber seal are clean and dust free. Cleaning can be accomplished by using water and a lint free wipe;
6. Remove the PM₁₀ head only from the inlet tube. Install a BX-305 or BX-302 leak test valve (or equivalent valve for auditing FRM samplers) onto the cyclone inlet and turn the valve to the OFF position to prevent any air from entering the inlet tube;
7. Press the <MOVE NOZZLE> key to lower the nozzle and press the <PUMP ON> key to start the pump;
8. Observe the flow reading on the screen, which should be dropping toward "zero". After 2-3 minutes, or when the reading has become stable, record the value. A value of 0.2 LPM or less indicates an acceptable leak test. If the leak test fails, this may mean that the nozzle and vane are dirty and must be cleaned. (Refer to Section 2.37.2.2.5 for the proper cleaning procedure.) After completion of the cleaning procedure, repeat the leak test, making sure that all rubber "O" rings (cyclone/leak check device) are in place and are not damaged. If the leak test fails again contact the ECB and the regional chemist;
9. Upon completion of the leak test, press the <PUMP OFF> key, release the vacuum and remove leak test device and replace the PM₁₀ head;
10. Press the <MOVE NOZZLE> key to move the nozzle to the up position and remove the rubber nozzle seal;
11. Carefully place the filter tape back into position under the nozzle, advance the filter tape approximately six (6) inches to provide a clean filter spot and rewind the filter tape to remove any slack. (Refer to Section 2.37.2.2.6 regarding filter tape replacement procedures);
12. Move the "latch" to release the "pinch" roller. (Note: BAM will not operate with "pinch" rollers in the up and locked position);
13. Press the <EXIT> soft key as necessary to return to the MAIN MENU;
14. Perform an instrument "Self Test": Press the <TAPE> soft key to enter the "Tape Menu". Press the <SELF TEST> soft key. The tests will take a couple of minutes, and the BAM-1020 will display the results of each tested item with an **OK** or a **FAIL** tag. If all of the test items are OK, the status will show SELF TEST PASSED (see figure 2);
15. The BAM 1020 will return to normal sample operation at the beginning of the next hour. Record all results on the e:log.

2.37.2.2.5 Nozzle and Vane Cleaning

The nozzle and vane (located under the nozzle) must be cleaned regularly to prevent leaks and measurement errors. The cleaning must be done at least once every 30 days and

each time the filter tape is changed. Some sites may require more frequent cleaning as determined by visual inspection of the filter spots that have previously collected sample (See Figures 3 and 4). Use the following steps to clean the parts. **Remember to “Down” the channel before any maintenance activities are performed.**

1. From the “Main Menu”, press the <TEST> soft key to enter the TEST MODE screen;
2. Using the red <ARROW> keys, scroll to PUMP and press the <SELECT> key. If the pump is running, press the <PUMP OFF> key;
3. If the nozzle is in the down position, raise the nozzle by pressing the <MOVE NOZZLE> key. Lift the “pinch” roller until the latch clicks to hold it in the up/locked position. Carefully remove the filter tape (if installed) from the nozzle area. It is not necessary to completely remove the tape from the unit;
4. With the nozzle up, use a small flashlight to inspect the cross-hair vane;
5. Clean the vane with a cotton-tipped applicator and isopropyl alcohol. Hardened deposits may have to be carefully scraped off with the wooden end of the applicator or a dental pick or similar tool;
6. Lower the nozzle in the TEST, PUMP menu by pressing the <MOVE NOZZLE> key. Manually lift the nozzle with your finger and insert another clean cotton swab with alcohol between the nozzle lip and the vane. Carefully release the nozzle, letting the nozzle press down onto the swab with its spring pressure;
7. Use your fingers to rotate the nozzle while keeping the swab in place. A few rotations should clean the nozzle lip. (See Figure 3);
8. Repeat the nozzle cleaning until the swabs come out clean;
9. Inspect the nozzle lip and vane for any burrs which may cause leaks or tape damage;
10. Perform a leak check (see Section 2.37.2.2.4);
11. Using a clean cotton swab with alcohol, clean the “pinch” rollers of any filter debris;
12. Reposition the filter tape between the nozzle and vane making sure that it is centered. Moving the latch to the left, to unlock the “pinch” roller;
13. Press <Exit> soft key to return to “Main Menu” and press the <TAPE> soft key to enter the “Tape Menu”. Press the <SELF TEST> soft key. The tests will take a couple of minutes, and the BAM-1020 will display the results of each tested item with an **OK** or a **FAIL** tag. If all of the test items are OK, the status will show SELF TEST PASSED as shown in the drawing below. If any item fails, the status will show ERROR OCCURRED.

```
02/08/1999      15:29:30
LATCH: OFF      TAPE BREAK: OK
CAPSTAN: OK     TAPE TENSION: OK
NOZZLE DN: OK   SHUTTLE: OK
NOZZLE UP: OK   REF EXTEND: OK
FLOW: OK        REF WITHDRAW: OK
Status: SELF TEST PASSED
TENSION SELF TEST EXIT
```

Figure 2 Self-Test Status Screen

14. Press the <EXIT> soft key to return to the “Main Menu”. The BAM will begin normal operation at the top of the next hour.

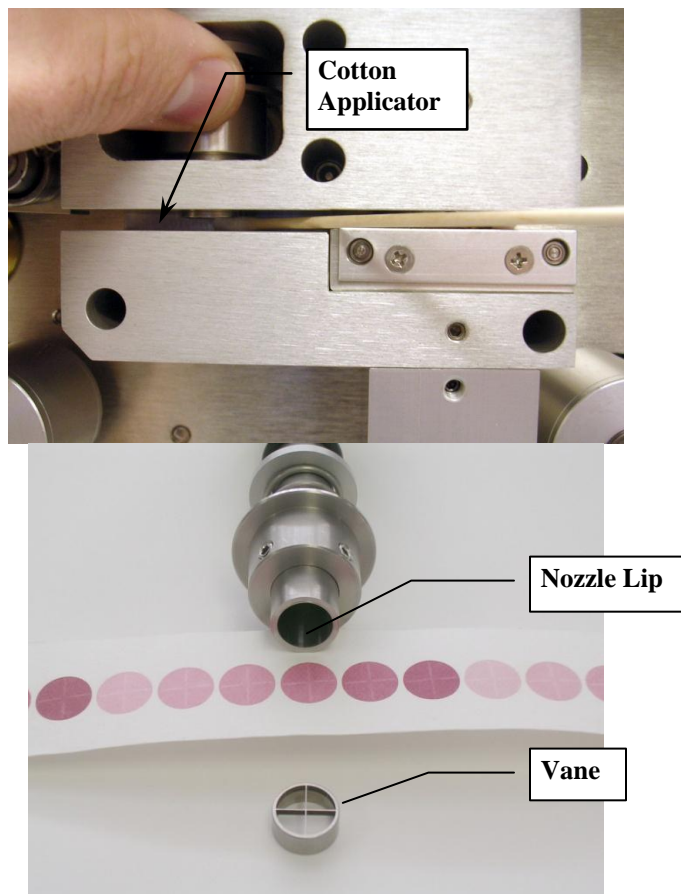

Figure 3 Nozzle Cleaning

Figure 4 below shows the difference between good and bad filter tape spots. The tape on the left is from a properly operated BAM-1020 with a clean nozzle and vane. Notice the particulate spots have very crisp edges, are perfectly round, and are evenly distributed.

The tape on the right is from a unit that has not been properly maintained. A spot of debris has built up on the vane, and is punching a pin-hole at the edge of each spot. These holes can allow beta particles to get through un-attenuated and negatively affect accuracy even if the nozzle is not leaking. The spots also show a "halo" effect due to air leaking in around the edge due to debris that has built up to the extent that the nozzle no longer seals correctly. These faults are easily corrected and prevented by keeping the nozzle and vane clean. Document activities on the e:log.

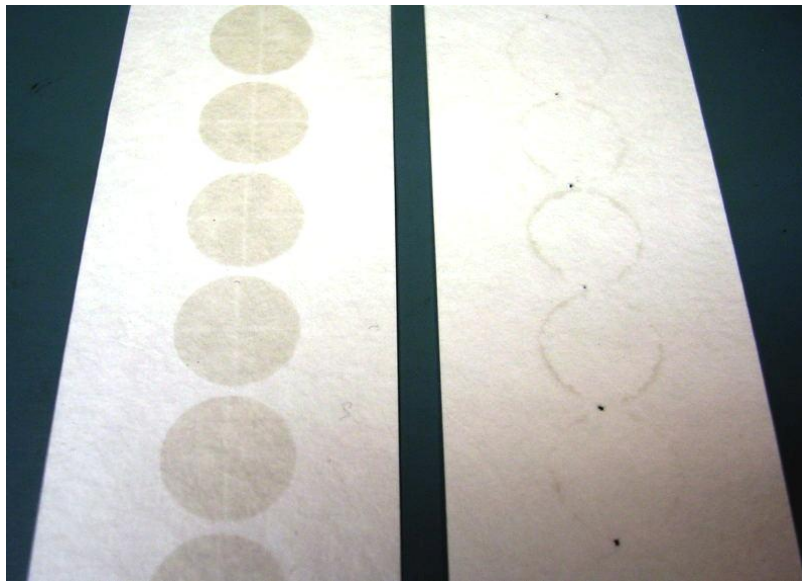

Figure 4 BAM-1020 Hourly Filter Tape Spots

2.37.2.2.6 Filter Tape Installation

A roll of filter tape must be loaded into the BAM-1020 for sampling. One roll of tape should last approximately two (2) months under normal operation. It is important to have several spare rolls of tape available to avoid data interruptions. It is the responsibility of the site operator to have at least one spare roll on hand. The tape should be changed when it approaches the end of the roll based on visual inspection during each site visit by the site operator. Additional rolls of filter tape can be obtained by contacting the ECB or the Central Office. **The used rolls of tape will be saved for potential post-sampling analysis. At the time of removal, the operator will write the date/ time directly on the filter tape after the last sampled spot. Place the tape in the plastic container bag and the box, record the site name, date and time on the filter box and return it the Projects and Procedures Branch in the Central Office for archiving.** The used filter

tape should never be “flipped over” or re-used! This will result in measurement problems. Loading a roll of filter tape is a simple matter using the following steps and referring to Figure 5 below:

1. From the MAIN MENU screen, press the <TAPE> soft key to enter the TAPE menu (Note: This is not the same as the TEST > TAPE menu). If the nozzle is not in the UP position, press the <TENSION> soft-key to raise the nozzle or with your fingers, manually lift and hold up.
2. Lift the rubber pinch roller assembly and latch it in the UP position (see Numbers 5 and 7 in Figure 5). Unscrew and remove the two clear plastic spool covers.
3. An empty core tube **MUST** be installed on the **left** (take-up) reel hub. This provides a surface for the used tape to spool-up on. Met One supplies a plastic core tube to use with the first roll of tape. After that, you can use the empty core tube left over from your last roll (right reel hub) to spool-up the new roll. Never fasten the filter tape to the aluminum hub.
4. Load the new roll of filter tape onto the **right** (supply) reel, and route the tape through the transport assembly as shown in Figure 5 below. Attach the loose end of the filter tape to the empty core tube with cellophane tape or equivalent.
5. Rotate the tape roll by hand to remove excess slack, then install the clear plastic spool covers. The covers will clamp the rolls to the hubs to prevent slipping.
6. Align the filter tape so that it is centered on all of the rollers. Newer units have score marks on the rollers to aide in visually centering the tape.
7. Unlatch and lower the pinch roller assembly onto the tape. **The BAM will not function if the pinch rollers are latched up, and it has no way of automatically lowering the roller assembly!**
8. Press the <TENSION> soft-key in the TAPE menu. The BAM-1020 will set the tape to the correct tension and alert you if there was an error with the process.

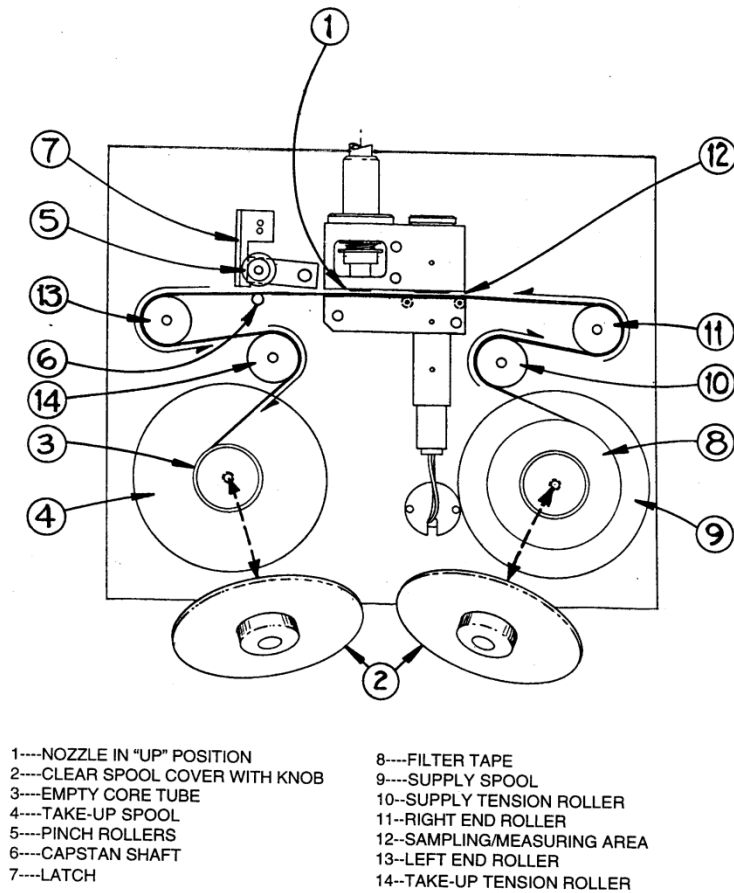

Figure 5 Filter Tape Loading Diagram

9. While still in the TAPE menu, press the <SELF TEST> soft key.
 The BAM-1020 has a built-in self-test function which automatically tests most of the tape control and flow systems of the unit. (The self-test can also be used if the operator suspects a problem with the unit.) The tests will take a couple of minutes, and the BAM-1020 will display the results of each tested item with an **OK** or a **FAIL** tag (see Figure 2). If all of the test items are OK, the status will show SELF TEST PASSED as shown in the drawing below. If any item fails, the status will show ERROR OCCURRED. If an error or Failed status occurs, address the item identified, and perform the SELF TEST again. If the problem cannot be resolved, call the ECB or the Central Office.
10. Press the <EXIT> soft key to return to the main menu. The BAM will automatically begin normal sampling operations at the top of the next hour. Record activities on the e:log.

2.37.2.2.7 Zero Background Test

The operator, with assistance from the ECB/CO, must perform a “zero background” test on the BAM 1020 within the first one to two months of initial operation at a site and subsequently on an annual basis. This simply involves collecting data for 72 hours with the two inlet heads removed and the “zero filter” (BX-302) device installed on the sample inlet. At the end of the 72-hour period, the data must be downloaded and the data statistically analyzed using a spread sheet template that is provided. At completion of the 72-hours, the two inlet heads are replaced and sampling continues as normal. The ECB/CO will contact the site operator when it is time to perform this task and supply specific instructions/guidance (see Appendix D). Record activities on the e:log.

2.37.2.3 Site Documentation and Data Handing

All BAM site visits, maintenance, calibrations, checks, leak checks and audit tasks must be documented completely and accurately to reflect the BAM QA/QC requirements, thus providing legally defensible data. All electronic files generated during BAM particulate sampling serve as quality control and quality assurance records that are required to validate and support the quality of the data collected. Applying the use of electronic operational files eliminates the need for paper or hardcopy files. Electronic files are transferred between PC's using the Internet or a data storage device of choice. Hardcopy files originating from these electronic files can be created to supplement the file management tasks. There are several topics that need to be addressed to insure the files are original and uncorrupted. The following guidelines serve as a method to create and store these files. Any problems, malfunctions, or abnormalities in BAM operations that cannot be corrected must be reported to the regional chemist, the CO BAM lead and the ECB.

2.37.2.3.1 Downloading Raw Data

Data must be downloaded at least once every 14-days. The PC (or lap top) that is used to download data must have the Met One “Comet” software loaded on the hard drive to communicate with the BAM unit. This software is available from the ECB. Upon installation, the Met One software will create a Met ONE directory. The Met One “Comet” software files are copied from the “Master” disk to the Met One directory on the C drive.

2.37.2.3.2 Set-Up

The Met One program must be setup to match the BAM RS232 parameters. The BAM-1020 data can be easily downloaded through the serial port using the “Comet” program. **Important Note: The BAM 1020 display must be on the Main Menu in order to establish communications.**

1. Connect the RS-232 port on the back of the BAM to your computer or laptop using the appropriate (supplied) cable. Connect to the Com1 serial port.
2. Open the “Comet” program (Start>Programs>Met One>Comet). The program

will ask "New Station" or "Existing". For a new station, click "Create" and then under "Manual Set-Up" click "Set-Up".

- Under **Station Name** enter a name such as "Millbrook" or "Mil";
- Under **Product** select "BAM 1020";
- Under **Port** select "COM 1";
- Under **Baud** select "9600";
- Under Phone Number leave blank;
- Click "OK".

(Note: After a "New Station" has been set-up, subsequent data downloading is performed by clicking on "Existing".)

3. The next screen will display two optional "Tabs". Select the "Data" tab. Under "Data Options" click "Retrieve Current".
4. In the next screen under "Retrieve Files" click "All" and under "Data Range" click "New". ("All" allows three files to be automatically downloaded...settings, alarms and data. "New" allows all data since the last download to be downloaded).
5. Click "Retrieve" to download all data since the last download. The download status screen will display progress and indicate when download is complete.
6. By default, the data is automatically stored to the "**My Documents**" directory. To change the data storage directory, first create a "new file" directory under the Met One directory, giving it a name such as "BAM Downloads". In the "Comet" main menu program click on "File" and then on "Settings". This opens the file settings dialog box. In the dialog box, either manually type in the desired directory (such as "C: Program Files>Met One>BAM Downloads") or use the "Browse" feature to locate the desired directory and click "OK".
7. When the download is complete, "Comet" automatically saves the downloaded files and assigns a unique file name to each file using the following convention:

Filename = station name_file_YYmmdd_HHMMss.Extension

Where:

- Station Name = Millbrook or Bryson City or ... (named during set-up);
- File = either "data", "alarm" or "settings";
- YY = year file was retrieved;
- mm = month file was retrieved;
- dd = day file was retrieved;
- HH = Hour file was retrieved;
- MM = Minute file was retrieved;
- ss = second file was retrieved; and
- Extension = **.txt** for alarm and settings files and **.csv** for the data file.

8. Go to the "My Documents" or "BAM Downloads" directory and open the files to make sure they were successfully saved. Review the data for any anomalies (see Section 2.37.2.3.5).
9. Copy the files to the P:drive at the end of each month, and notify the

- has encountered a problem. Check the datalogger.
- M MAINTENANCE:** This is a user-set data flag which indicates that calibration or testing was performed during the flagged hour. M flags cause the digital concentration to read full-scale for that hour (i.e., 995).
- I INTERNAL CPU:** This indicates an error in the mass concentration calculation by the central processor. Contact the ECB/CO BAM Lead if these errors begin to occur frequently. This may require factory repair.
- L POWER FAIL:** This error occurs any time power is cycled or lost, even momentarily. Frequent "L" errors usually indicate poor quality AC power. In some cases these errors can be generated by electrical interference (such as large radio antennas or motors) causing an internal reset in the BAM-1020. This error also causes the digital concentration value to go full-scale.
- R REFERENCE MEMBRANE:** This error indicates that the reference membrane assembly is not physically extending and retracting properly during the hourly automatic span check.
- N NOZZLE STUCK TIMEOUT (or Delta-T exceeded):** This error indicates that the nozzle motor is not operating. **NOTE:** The nozzle motor lifts the nozzle, but the nozzle is lowered only by its spring. So it is possible for the nozzle to become stuck in the UP position without generating an error! Proper maintenance and inlet alignment prevents this. The "N" error is also used to indicate that the Delta-Temperature set-point was exceeded. This occurs if the sample air temperature (measured below the filter tape) is hotter than the ambient air by at least one degree above the set-point value. This is due to the normal heating of the sample air by the smart heater. In this case, the error is used to simply flag the data. Frequent errors may indicate that the set-point is set too low. In most applications Delta-T control is disabled entirely as is the case here.
- F FLOW ERROR:** This error occurs if the average air flow over the sample period was out of the limits set by the **FRI** (low limit) and **FRh** (high limit) values. The error will also be generated if the flow during any part of the sample period goes out of regulation by more than 5% for more than 5 minutes, or by more than 10% for more than 1 minute. In the later case, the sample is stopped as well. Momentary changes in airflow do not usually trigger the error. This error may begin to occur if the vacuum pump is wearing out, if the muffler is clogged, or due to a fault with the flow sensor, flow controller, or air tubing. The "F" error is also used to indicate if the ambient temperature or barometric pressure sensor has failed or is incorrectly connected.
- P PRESSURE DROP EXCESSIVE:** This error indicates that the vacuum beneath the filter tape has exceeded the limit set by the **AP** value. This is almost always caused by high concentrations, or certain types of particulate clogging the filter tape. When this error occurs, the BAM stops the pump to prevent overheating, completes the measurement early, then waits for the top of the next hour. To increase the amount of particulate which can build up on the tape before this occurs, set the **AP** value higher.
- D DEVIANT MEMBRANE DENSITY:** This error indicates that the reference membrane span check measurement (**m**) for that hour was out of agreement with

- the expected value (**ABS**) by more than $\pm 5\%$. If these errors start to occur regularly, it could indicate that the beta detector is beginning to wear out. It can also be caused by a dirty or damaged membrane, or by a membrane assembly that is not extending or retracting fully. Also sometimes called a **BAM CAL** error.
- C COUNT ERROR:** This error indicates that the beta particle counting system is not operating properly, and is activated if the beta count rate falls below 10,000 per 4 minutes. The beta count rate through clean filter tape is usually more than 800,000 per 4 minutes. This error could occur if the beta detector has failed or if something is blocking the beta particles, such as a stuck membrane assembly or debris.
- T TAPE BREAK:** This error indicates that the filter tape is broken or has run out. This error is also generated if the pinch roller assembly has been left latched in the UP position when a measurement cycle starts.

2) "Alarm".txt file

This text file lists all alarms that have occurred in chronological order. This information is used to assist in the diagnosis of any instrument malfunction(s) and in the monthly review of the AQS monthly data summary reports as to the proper application of any necessary "Null Codes".

3) "Settings".txt file

This text file lists all of the BAM settings that were entered during instrument set-up and must not be changed by the operator. This file must be reviewed and compared to the last download to verify that the settings have not changed.

2.37.2.3.4 File Management

All site files generated in the field will be stored on a dedicated PC in the Regional office, in a folder named for the BAM official operations files (Example: MQ_BAM_Official Files). These files should be transferred to the Official File on a frequent and regular schedule as established by the Region. This is necessary to prevent the potential loss of such files from the field computer and to maintain a "paper trail" for providing defensible data. This also makes the data easily and readily available for review by the Regional Chemist and transfer to the P: drive for review by the CO. The files on the site/operator's PC can be copied and transferred to the common hard drive and/or be transferred as attachments in email for storage in the official folder.

Field operators must have a PC (or lap top) to generate the elog files from a Microsoft Excel template file. The BAM "**Site_Visit**" and "**Flow_Leak**" elog sheets are provided by the CO and updated periodically. The file naming protocol is provided below. **A formalized file naming convention has been established through consensus of the regions and the CO and should be used by all regions.**

Opening, naming and storing the site files. The elog template file used at the site should be stored on the PC used for field operations by the field technician. To access this file, open the elog template file using Excel. Every time a "new elog work book" is

filled out using the template, it must be renamed and saved as a separate and complete workbook (all sheets, i.e., tabs, saved) to preserve the record. Do not copy over a previously completed elog. (refer to the Logbook file naming convention "Policy Memorandum" dated January 1, 2011 which is located in the DAQ internal web site and summarized below.)

Renaming - Saving the elog

1. Open the elog workbook template file using Excel.
2. Left click the "file" toolbar icon. Scroll down to "save as" and left click.
3. Under file name (highlighted in blue) change workbook file name using the following format: Logger ID BAM25 Date Activity (example: MQ BAM25 20110930 AX.xls which equates to a BAM flow rate verification at Millbrook on September 30, 2011).
4. Change "save in" location to operator's choice of folders (example: previously created folder named "BAM25").
5. Left click "save"
6. Find the tab needed for the task involved. The first tab selected should be the "Site_Visit". Fill in information as indicated.
7. Open the tab named "Leak_Flow" and fill in information as indicated;
8. Save the workbook when finished entering data, referring to #2, # 4 and #5 above.

The site files will be transferred every two weeks, and backed up on a monthly basis. This serves as a backup system in the event the official PC fails or is removed or the site files are damaged. These files will be retained for a minimum of **five** years. When the need arises to review a file for data validation or site operations the official folder is used or a hardcopy is created from this file.

2.37.2.3.5 BAM Monthly Data Validation.

As of the 2nd quarter of 2010, the monthly data summaries are provided to the ROs by the CO in an electronic format using an Excel spread sheet. At the end of the descriptive file name provided to the RO will be the number _1 (example: file name _1.xls). The RO must open this file, rename the file by changing the number _1 to _2 and then save the file. After the RO has reviewed and edited the data, the edited file (_2) is resaved to the shared P:drive. This edited file is reviewed by the CO, edited further if needed after consultation with the RO and then saved after renaming the file using a _3. The fully edited file data are then uploaded into AQS by the CO.

The monthly data validation checks that will be performed are:

1. Checking the two highest 1-hour values of each day;
 2. Providing missing data;
 3. Documenting the invalid data as to reason with proper null code; and
 4. Identifying data that may be the result of an exceptional event.
- 1) Referring to the BAM25 sheet, the site operator will review and compare the **two** highest 1-hour concentrations of PM_{2.5} data from the AQS summary data (for each 24-hour period) with the corresponding BAM downloaded data files. Verify the AQS 1-hour data values using the BAM data download files by typing, in the space provided, the BAM downloaded 1-hour values above the two highest AQS values for each day. Values that do not agree within $\pm 1 \text{ ug/m}^3$ must be identified in the notes section at the bottom of the AQS BAM25 data summary page. Five or more observed differences outside of this range in any given month and/or subsequent months may require the analog output of the monitor to be recalibrated. In this case contact the ECB.
 - 2) The BAM downloaded data will be used to supplement the AQS monthly data summary report in those cases when the AQS polled summary report has missing data. Each RO has the responsibility of inserting any missing data into the monthly summary report. Data for BAM25 can be easily retrieved from the downloaded data file (see section 2.37.2.3.1).
 - 3) The AQS monthly concentration data summary report contains BAM data that has been retrieved from the primary data logger by the CO using E-DAS software. **This report is reviewed by the site operator and the regional chemist for accuracy to insure that the AQS database contains no inaccurate data.** The BAM data download files (data and error files) also contain information that can serve as justification for data invalidation. These files provide a time base for verifying when the BAM was "on" or "off" line due to QC checks, maintenance and/or operational error flags. Other parameters to consider when reviewing the BAM downloaded data include: 1) "Qtot" (must be $0.7 \text{ m}^3 \pm 0.028$). The "Qtot" is particularly important in data validation, (see Section 2.37.2.2.2); 3) "RH%" (should be nominally $\leq 35\%$), Occasionally values above 35 may be observed, but values that are consistently above 35 should be noted and the ECB/CO BAM Lead should be contacted; and 4) "Shelter Temperature" (should not vary more than 3° C over any given 1-hour sampling period). These values are recorded through E:DAS and are not part of the download.

The AQS monthly data summary report lists the BAM one-hour concentrations for each day of the month. The BAM downloaded files will list the 1-hour average concentration values along with a listing of any error codes. These parameters are used to edit the AQS monthly data summary report and to verify

that the data is correct. Data corrections or invalidation's are edited by the RO on the AQS monthly summary report. If data in one or more spread sheet cells is invalid, replace it with the proper null code by typing the null code in the spread sheet cell(s) on the monthly AQS summary report. Use the same procedure for any missing valid data, by typing in the correct value obtained from the downloaded data.

- 4) In some cases, "valid" data that are judged to be out of the ordinary are retained and an informational flag is added in AQS by the CO. An example would be high concentration values resulting from a wild fire and identified as an exceptional event. EPA has recently begun applying stricter standards for what it will accept as an exceptional event. In any case where the RO wishes data to be considered "exceptional", the RO should gather sufficient documentation to support the claim in accordance with a policy memorandum from the CO dated June 29, 2007. Possible/likely exceptional events experienced in North Carolina along with the informational AQS qualifier code include: structural fires, **IP**; prescribed burns, **IM**; wild fires, **IT**; and fireworks, **IH**. Unusually high concentration values that may be the result of an exceptional event must be noted as such on the AQS monthly data summary reports, but not deleted. Any exceptional event data will be flagged in AQS by the CO using the appropriate qualifier code.

Table 1 Commonly Used Null Codes (partial list)

Null Code	Description
AH	Sample Flow Rate Outside of Control Limits (16.7 LPM \pm 0.067 LPM) Qtot Outside of Control Limits (0.700 \pm 0.028)
AN	Equipment malfunctions, disconnected coupling, broken tubing, etc. RH% consistently above nominally 35% or displaying negative values
AV	Power failures
AX	Flow Check Performed
AZ	Quarterly Flow Rate Audit Performed by RO or ECB Audit
BA	Scheduled/Unscheduled Maintenance and/or Repairs (cleaning, data download, flow/leak checks etc.)
BJ	Operator errors that produce missing data or invalid data
AE	Shelter Temperature Outside Limits (20-30 °C) (>3 °C change over any 1-hour sampling period) If either occur, contact the ECB/CO BAM Lead
AS	Poor Quality Control Results (failed leak test, flow outside limits, etc.)
AT	Annual/Semi-annual Calibrations Performed by the ECB

2.37.2.4 BAM Preventive Maintenance

Preventive maintenance tasks need to be performed on a routine schedule to ensure the proper operation of the BAM monitor and the collection of high quality data.

Maintenance activities are:

2.37.2.4.1 Inlet Cleaning: The PM-10 Inlet and the 2.5 Very Sharp Cut Cyclone (VSCC) must be cleaned at a minimum of once every 30 days. To clean the

PM-10 inlet and the 2.5-VSCC, remove them from the sample down tube. Disassemble the units, clean the parts using a soft bristle brush and/or lint free wipe with deionized water or isopropyl alcohol. The units are considered clean when no particulate matter is visible. Check the condition of all "O" rings and replace them if damaged. Ensure that "O" rings are in place and reassemble the PM-10 inlet head and the VSCC and reinstall them on the sample down tube. **Document the cleaning in the e:log.**

2.37.2.4.2 Shelter Temperature Control: Check the operation of the heating/cooling units of the BAM shelter and the exhaust fan once every 30-days. Make sure that the exhaust vent filter is clean allowing free flow of air. The shelter temperature should be kept between 20 and 30 degrees Celsius and not vary more than ± 3 degrees over any one-hour sampling period. **Document the cleaning and tape change in the e:log.**

2.37.2.4.3 Nozzle/Vane Cleaning: Clean the nozzle and vane at least once every 30 days at time of leak check and when the filter tape is changed (Refer to section 2.37.2.2.6). **Document the cleaning in the e:log.**

2.37.2.4.4 Capstan and Pinch Roller: Clean the Capstan Shaft and Pinch Roller every 30 days and at time of filter tape change out. (Refer to Sections 2.37.2.2.5 and 2.37.2.2.6). **Document the cleaning in the e:log.**

2.37.2.4.5 Filter Tape: Inspect filter tape looking for sample "spots" with sharp distinct edges and the absence of puncture holes. **Document the cleaning in the e:log.**

Appendix A

Diagram of BAM 1020 System

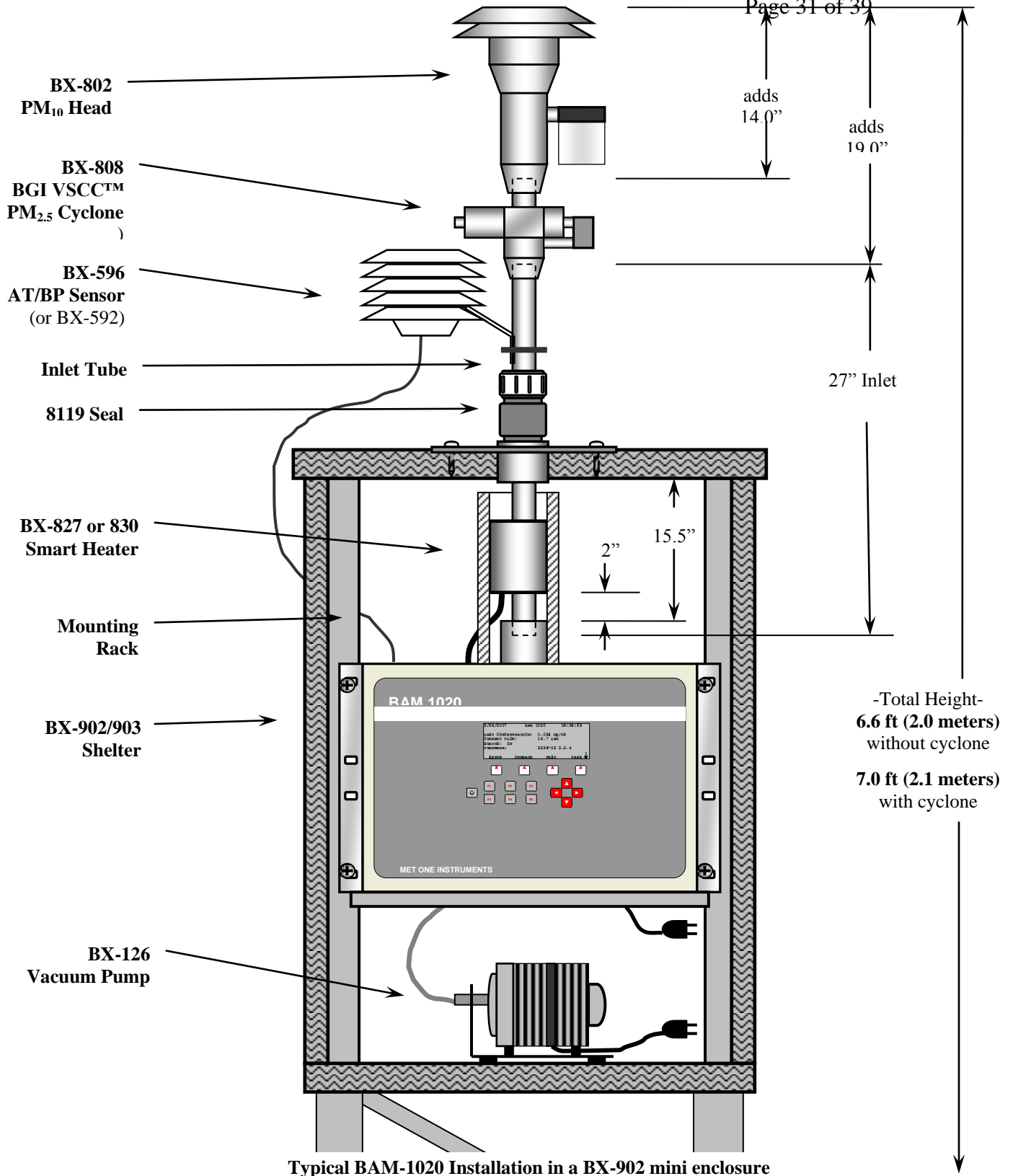

Appendix B

Summary of Scheduled Activities

Scheduled Activities

Item #	Activity	Frequency	Details found in Section...
1	Site Visits	Nominally every 14-days or less	2.37.2.2.1
2	Download and Review Data	Nominally every 14-days or less	2.37.2.3 & 2.37.2.3.5
3	Review Polled Data	Daily	2.37.2.2
4	Flow Check	Nominally every 30-days or less	2.37.2.2.2
5	Leak Check	Nominally every 30-days or less and with filter tape change	2.37.2.2.4
6	Flow Audit	2 nd Month of Each Quarter	2.37.2.2.3
7	Nozzle/Vane Cleaning	Nominally every 30-days or sooner if needed	2.37.2.2.5
8	Inlet Cleaning	Nominally every 30-days or less	2.37.2.4.1
9	Replace Filter Tape and send old tape to CO BAM Lead	Approx. every 2 Months	2.37.2.2.6
10	Post the downloaded data & e:logs on the P:drive	Once per month for preceding month	2.37.2.3
11	Review/Correct AQS Summary Reports	Once per month for preceding month	2.37.2.3.5
12	Perform Background Test	At least annually	2.37.2.2.7 and Appendix D

Appendix C

E:LOG

BAM PM 2.5 SITE VISIT / ROUTINE CHECK

(Version 1: July 25, 2008)

White boxes to be checked or filled in. All other boxes are locked

Site:		Name	Date:		mm/dd/yy
Local Time:		hh:mm:ss	Operator:		Initials
BAM Serial Number:					
VSC Cyclone Serial Number:					
PM 10 Inlet Head Serial Number:					
Primary Datalogger Serial Number:					
Operational Parameters					
	As Found	As Left			
BAM Date					
BAM Time					
Status					
Flow Rate (LPM)					
Average Flow Rate (LPM)					
Flow CV (%)					
Ambient Temperature: (degrees C)					
Ambient Pressure (mmHg)					
Last C (conc., ug/m3)					
Last M (Calib. Value, mg/cm2)					
BAM RH (rel. Humidity, %)					
Shelter Temp. (degrees C)					
Data Logger					
Logger Time					
Shelter AC/Heater Working	<input type="checkbox"/>	Yes	<input type="checkbox"/>	No	
Data Downloaded to PC?	<input type="checkbox"/>	Yes	<input type="checkbox"/>	No	
Very Sharp Cut 2.5 Cyclone Cleaned?	<input type="checkbox"/>	Yes	<input type="checkbox"/>	No	
PM 10 Inlet Cleaned?	<input type="checkbox"/>	Yes	<input type="checkbox"/>	No	
Filter Tape Replaced?	<input type="checkbox"/>	Yes	<input type="checkbox"/>	No	
Smart Heater Warm to the Touch	<input type="checkbox"/>	Yes	<input type="checkbox"/>	No	
Error Message	<input type="checkbox"/>	Yes	<input type="checkbox"/>	No	
Nozzle/Vane/Pinch Rollers Cleaned	<input type="checkbox"/>	Yes	<input type="checkbox"/>	No	
"Self Test" Passed	<input type="checkbox"/>	Yes	<input type="checkbox"/>	No	
Exceptional Event Observed?	<input type="checkbox"/>	Yes	<input type="checkbox"/>	No	
NOTES:					
Notes go here					

BAM PM 2.5 Flow and Leak Checks

Version 1: July 25, 2008

White boxes are for checking or entering values. All other boxes are locked. Dark boxes are linked to "Site_Visit" tab

Check Appropriate Box(es): Leak Check Flow Check
 Flow Audit Use Different FTS, manometer, temp./press. readout and Operator.
 If Flow Audit is checked, do not check Flow Check or Leak Check.

Site: site code Date: mm/dd/yy
 Time: hh:mm:ss Operator: initials

BAM Serial Number: Primary Datalogger Serial #:

BAM FLOW RATE

Manometer ID No.	<input type="text"/>	Certification Date:	<input type="text" value="08/01/07"/>	Expiration Date:	<input type="text" value="07/31/08"/>	Days Left:	<input type="text" value="-25"/>	Warning
Pressure Readout Device ID No.	<input type="text"/>	Certification Date:	<input type="text" value="08/01/07"/>	Expiration Date:	<input type="text" value="07/31/08"/>	Days Left:	<input type="text" value="-25"/>	Warning
Temp. Readout Device ID No.	<input type="text"/>	Certification Date:	<input type="text" value="08/01/07"/>	Expiration Date:	<input type="text" value="07/31/08"/>	Days Left:	<input type="text" value="-25"/>	Warning
TOTAL FLOW FTS ID No. (FTS for 16.67 LPM Required)	<input type="text"/>	Certification Date:	<input type="text" value="08/01/07"/>	Expiration Date:	<input type="text" value="07/31/08"/>	Days Left:	<input type="text" value="-25"/>	Warning

Slope (M): mm Hg
 Intercept (b): Atmospheres

AMBIENT CONDITIONS

Ambient Temperature (degrees C): Must Match FTS Pressure Units
 Ambient Temperature (degrees K): Ambient Pressure:

FLOW Calculations

BAM Flow Reading (LPM)	Manometer Delta P (inches H2O)	Actual FTS Calculated Flow (LPM)	BAM Reading minus Actual (LPM)	BAM vs Actual (% Difference)
16.00	4.7	16.855	-0.855	-5.07

Flow Acceptance Criteria: Total Flow Must = 16.67 +/- 1.0 LPM
 Actual Flow Status: Total Flow OK MFC Status: MFC OK
 Flow Check/Audit Passed: Yes No

LEAK CHECK

Follow the procedure as provided in the QA/SOP. The leak check can be performed with the filter tape in place or with the filter tape removed and rubber seal in place.

Leak Check With Filter Tape In Place

As Found Attempt # 1
 Beginning Flow (LPM): As Found Attempt # 1
 Ending Flow (LPM): Beginning Time (mm:ss):
 Ending Time (mm:ss):
 Leak Check Passed: Yes No

As Found Attempt # 2
 Beginning Flow (LPM): As Found Attempt # 2
 Ending Flow (LPM): Beginning Time (mm:ss):
 Ending Time (mm:ss):
 Leak Check Passed: Yes No

As Left After Filter Tape Change
 Beginning Flow (LPM): As Left After Filter Tape Change
 Ending Flow (LPM): Beginning Time (mm:ss):
 Ending Time (mm:ss):
 Leak Check Passed: Yes No

Leak Check With Filter Tape Removed and Rubber Seal in Place

Attempt # 1
 Beginning Flow (LPM): Attempt # 1
 Ending Flow (LPM): Beginning Time (mm:ss):
 Ending Time (mm:ss):
 Leak Check Passed: Yes No

Attempt # 2
 Beginning Flow (LPM): Attempt # 2
 Ending Flow (LPM): Beginning Time (mm:ss):
 Ending Time (mm:ss):
 Leak Check Passed: Yes No

Leak Check Acceptance Criteria
 Leak Check With Filter Tape in Place: BAM Flow reading of less than 0.75 LPM
 Leak Check With Filter Tape Removed and Rubber Seal in Place: BAM Flow reading of less than 0.20 LPM

Appendix D

Annual Background Test Procedure

Annual Background Test Procedure

A summary of the test procedure is provided below:

Materials needed will include: 1) Metone Excel "Background Test Template", 2) Latest revision of the BAM manual and 3) The background test HEPA filter assembly. These materials can be provided by the CO.

- 1) Watch the weather forecast looking for 4-5 days of good weather, no major fronts coming through and no rainy periods. Typical isolated thunderstorms will be ok.
- 2) The test should run for at least 72 hours (3 days). Pick any days you like for scheduling purposes. Since 72 good data points are required, nominally 80-90 would provide a safe margin. Inform the CO when the test begins and ends.
- 3) From the main menu of the monitor, go to <Setup>, then go to <Calibrate> menu and see current <BKGD> setting. Record this value on the spread sheet template or just remember and enter later.
- 4) Change the BKGD value to 0.0000 and push the save button. The negative sign is fixed in the software so a -0.0000 is ok. To double check, exit back to the main menu and then go to <Setup> and then <Calibrate> and see if the BKGD value is 0.0000. Exit back to the main menu.
- 5) Clean the nozzle/vane and pinch rollers as usual, perform a flow and leak check as usual to make sure everything is operating properly before starting.
- 6) With the PM10 head and cyclone removed, put the background test HEPA filter assembly on the inlet making sure that the on/off valve is open.
- 7) Being in the main menu, the test period will automatically begin at the top of the next hour. It would be prudent to wait for the run to complete to see if monitor is working properly and to see the first data point. The hourly data should be around zero, a little negative or a little positive. The first 1-2 hours may be voided if necessary.
- 8) After collecting at least 72 hours of good data, remove the background test HEPA filter assembly and replace the PM10 head and cyclone. Download the data for entry into the spread sheet template.
- 9) Something to keep in mind when using the spread sheet...the **values must be entered in milligrams and the download values are in micrograms**. Make the necessary conversion to milligrams by dividing by 1000. Review the download values and delete any obvious outliers such as "995s" etc. and possibly the first few values. The spread sheet calculations are setup for 72 data points.
- 10) From the main menu of the monitor, go to <Setup>, then go to <Calibrate> menu and see current <BKGD> setting which should be -0.0000. Enter the new BKGD value as milligrams and must be a negative number. After entering the new value push **Save** and then double check to make sure the update was successful.

- 11) Being in the main menu, the monitor will begin sampling at the top of the next hour.
- 12) E: MFail the completed spread sheet to the CO BAM Lead.