

Thermo Environmental Model 146C Calibrator Certification

Approval Sign-Off Sheet

I certify that I have read and approve of the contents of this version of the Thermo Environmental 146C Calibrator Certification QAP/SOP with an effective date of September 1, 2011.

Joette Steger, PPB Supervisor: Joette Steger 9/7/2011
Donnie Redmond, Ambient Monitoring Section Chief: Donnie Redmond 9/8/2011
Frank Stellitano, ECB Supervisor: Frank R. Stellitano 9/7/2011
Carlton Blakley, Central Office Lead: Carlton Blakley 9/1/11

Table of Contents

2.3.4	Thermo Environmental Model 146C Calibrator Certification QA Procedure....	4
2.3.4.1	ECB Certification/Verification for TEI Model 146C Dynamic Gas Calibrator4	
2.3.4.2	146C Leak Check.....	4
2.3.4.3	Mass Flow Controller Check	7
2.3.4.4	146C Certification.....	7
2.3.4.5	146C Zero Air Certification.....	8
2.3.4.6	146C Zero Air Verification.....	20
2.3.4.7	Zero Air Data Collection	23
2.3.4.8	146C Gas Certification	26
2.3.4.9	146C Gas Verification	38
2.3.4.10	Gas Data Collection	42
2.3.4.11	146C Cleaning	45
2.3.4.12	146C Routine Maintenance.....	45

Table of Figures

Figure 1	Model 146C Hardware Configuration, Standard Gas Dilution System	53
Figure 2	146C Front View	54
Figure 3	146C Rear View	54

2.3.4 Thermo Environmental Model 146C Calibrator Certification QA Procedure

Note: The following is a list of "significant changes" from Revision 11.9.

- 1) QA updated per QAP/SOP 2.39 "Standard Operating Procedure (SOP) for Preparing Quality Assurance Plans/SOPs".
- 2) Electronic Calibration Branch (ECB) updates.
- 3) US Environmental Protection Agency (USEPA) comments.

2.3.4.1 ECB Certification/Verification for TEI Model 146C Dynamic Gas Calibrator

The Thermo Environmental Model 146C Dynamic Gas Calibrator supplies precise levels of ozone, carbon monoxide, non-methane hydrocarbons, sulfur dioxide, nitric oxide, and nitrogen dioxide and tolerance values for which the instrument's precision is certified. The gas levels are used to calibrate instruments that perform zero, precision and Level 1 span checks, audits, and multipoint calibration of these gases. For detailed operational procedures, maintenance procedures and tolerances consult the Model 146C Instruction Manual.

The 146C "audit calibrator" must be certified one and one half quarters (18 weeks, not to exceed 126 days between consecutive certifications) and the "field calibrator" certifications are good for 9 months.

Model 146C calibrator and setup to be equilibrated for 24 hours prior to certification.

All maintenance, repairs and audits performed on the 146C calibrators are manually recorded on the AQ 109 form and in device specific logbooks. The logbooks and forms are stored at the ECB in the Site File. Zero air and gas certification / verification are recorded in Excel spreadsheets and data files are stored on a flash drive at the ECB facility.

2.3.4.2 146C Leak Check

The Leak Check (s) must be performed before a certification.

Equipment Required:

Teflon tubing and Swagelock caps - 1/4"

1. Connect 146C to 115v AC power source. Turn on the power to the 146C. Let the unit stabilize. Leak check the Zero Air with **Gas A Dilution** on. Connect the zero air supply to the zero air "**inlet port**" on the rear of the 146C (see pg. 55, Figure 3 146C Rear View) making sure the zero air supply is set to deliver air at 8 psi or less.

Caution: Failure to reduce pressure to below 8 PSI when output is capped can cause damage to the Model 146C.

2. Press **Menu** to get to the 146C Main menu, select **Mode** <ENTER>, change mode to "**Service**" <ENTER>.
3. Steps to put zero air flow between 30-50% full-scale.
From the 146C main menu:
Select "**GAS A**" <ENTER>,
Scroll down to "**MANUAL**" <ENTER>,
Select "**ZERO AIR**" <ENTER>,
Change GAS A MAN ZERO AIR: FLOW SCCM to between 30-50% of full-scale, press "**RUN**",
Select "**GAS A**",
Change "**SPAN**" to "**MANUAL**" <ENTER>
Press "**Run**" (change to the run screen showing target and actual flows; watch to see that the flow rises to the set level).

```
GAS OFF SCCM      0.00
TARGET           100.00
Z AIR SCCM       150.
TARGET           4000.
```

RUN 2 SCREEN

4. Cap both output fittings of the ports labeled "VENT" and "OUTPUT" (see pg. 55, Figure 3 146C Rear View).
5. Zero airflow should gradually decrease to below 2% of MFC full scale if no leak is present. When the flow falls below 2% of full scale, slowly remove the "OUTPUT" cap to release pressure.
6. Steps to put zero air flow back to zero.
From the 146C main menu:
Select "**GAS A**" <ENTER>,
Scroll down to "**MANUAL**" <ENTER>,
Select "**ZERO AIR**" <ENTER>,
Change GAS A MAN ZERO AIR: FLOW SCCM to zero (0), press "**RUN**",
Select "**GAS A**",
Change "**SPAN**" to "**MANUAL**" <ENTER>
Press **Run** (to change to the run screen showing target and actual flows; watch to see that the flow drops to the set level).

7. Leak check GAS Mass Flow Controller (MFC) by switching the zero air line to the **GAS A** inlet and capping the zero air inlet (see pg. 55, Figure 3 146C Rear View) making sure the zero air supply is set to deliver air at 8 psi or less. Set flow for 80-90% of the GAS MFC full scale.

Caution: - Failure to reduce pressure to below 8 PSI when output is capped can cause damage to the Model 146C.

8. Press **Menu** to get to the 146C Main menu,
Select "**GAS A**" <ENTER>,
Scroll down to "**MANUAL**" <ENTER>
Select "**GAS SCCM**" <ENTER>

```
GAS A MAN GAS FLOW:
SCCM                100.00
++ INC/DEC
```

Manual Gas Screen

Change GAS A MAN GAS SCCM to between 80-90% of full-scale, press "**RUN**",
Select "**GAS A**",
Change "**SPAN**" to "**MANUAL**" <ENTER>
Press "**Run**" (to change to the run screen showing target and actual flows; watch to see that the flow rises to the set level).

```
GAS A SCCM          85.00
TARGET              85.00
Z AIR SCCM          0.00
TARGET              0.00
```

Run Screen

9. Establish flow through the analyzer again. Once the flow develops, cap the "**OUTPUT**" (see pg. 55, Figure 3 146C Rear View) to stop the flow.
10. The gas flow should gradually decrease to a reading less than 2% of MFC full scale if no leak is present. Since the sum of the volumes of the mixing and reaction chamber is about 1/3 liter, it will typically take a few minutes for the flow to fall below 2% of full-scale in a leak-free system.
11. When the flow falls below 2% of full scale, slowly remove the "**OUTPUT**" plug to release pressure.

12. Set zero air and gas flows to 0%.
13. Turn off the zero air and remove caps.
14. If the system is found to have a leak, the location can easily be found by following a systematic approach. For the Model 146C, a systematic approach starting at the mass flow controllers and capping-off more and more of the system, seems to work the best. It has also been found to be helpful to leak check the reaction and mixing chambers independently. Connecting these chambers directly to the low flow mass flow controller and capping the outlet of the chamber most readily accomplish this. If the mass flow controller fails the leak test and no apparent leaks are found, perform mass flow controller alignment on page 49 and re-perform 146C leak check.

2.3.4.3 Mass Flow Controller Check

If there is a 146C with suspect MFC(s), there is an MFC alignment procedure (pg. 49). Do the alignment procedure **before** starting the 146C certification.

2.3.4.4 146C Certification

The Alicat 10 M-SLPM-D and the 20 M-SLPM-D are used to certify the 146C 10 and 20 LPM **zero** air mass flow controllers respectively. The Alicat 50 M-SCCM-D is used to certify the 50 SCCM **gas** mass flow controller and the 100 M-SCCM-D is used to certify the 100 SCCM **gas** mass flow controller. The 146C certification is a two-day procedure. Whichever mass flow controller is done first air or gas; the procedure will include a **146C Verification**.

Alicat Recalibration

The recommended period for recalibration for the Alicat mass flow device(s) is once every year. Providing that the CLEAN, DRY, and NON-CORROSIVE mantra is observed, this periodic recalibration is sufficient. A label located on the back of the meter lists the recalibration due date. The meter should be returned to the factory for recalibration near the listed due date. Before calling to schedule a recalibration, please note the serial number on the back of the meter.

All certification equipment must be traceable to National Institute of Standards and Technology (NIST). A 'Certificate of Analysis' must accompany each piece of equipment. These certificates should be kept in a central file at the laboratory.

Logbook records for the Alicat (s) will include the certifications and the complete repair records for the instrumentation.

2.3.4.5 146C Zero Air Certification

The Alicat 20 M-SLPM-D is used to certify the NCore 146C 20 LPM zero air mass flow controllers. The Alicat 10 M-SLPM-D is used to certify the non NCore 146C 10 LPM zero air mass flow controllers.

The 146C adjusts its outputs using an algorithm derived from the pressure and temperature compensated volumetric flows.

In order to certify the mass flow meter section of the zero mass flow controllers, a NIST traceable flow meter is required. Annual certification is recommended for all flow calibration devices. The term certification means determining the actual flow versus the flow settings for seven points (5%, 20%, 35%, 50%, 65%, 80%, and 95%) equally spaced flows along the range of the device.

- A seven-point certification is performed and documented in the 146C certification excel spreadsheet. The 20% to 95% points should fall within $\pm 2\%$ of the actual flow.
- The entire Zero Air Certification is a minimum of 4 hours and 40 minutes long

Certification gas used for 10/20LPM zero air mass flow controllers is **Air**.

The following provides a step-by-step procedure for certifying the zero air mass flow controller of the 146C calibrator:

- a. Select the appropriate Alicat for the certification.
 - b. Connect clean, zero air (30 psi) to "**Zero Air**" inlet port, cap "**Vent**", "**GAS A**", "**B**" and "**C**" ports on the 146C back panel (see pg. 55, Figure 3 146C Rear View).
- Connect power to the Alicat and configure the Alicat to data logger, serial port #2. Connect the 146C serial port to the data logger serial port #3. Cap both ends of the Alicat and let the instrument stabilize (~ 1hour).
 - **Tare** - Perform an initial flow tare of the zero air Alicat. Pushing the labeled "**Tare**" button for about 5 seconds in the upper right hand corner (Figure 1) tares the flow meter and provides it with a reference point for zero flow. **Note:** It is critical to have a stable tare before starting the air certification procedure. This is a simple but important step in obtaining accurate measurements.

It is good practice to "zero" the flow meter each time it is powered up. If the flow reading varies significantly from zero after an initial tare (**Zero no flow criteria:** 10/20LPM = 3scm), give the unit a minute or so to warm up and re-zero it. May have to hit "TARE" several times.

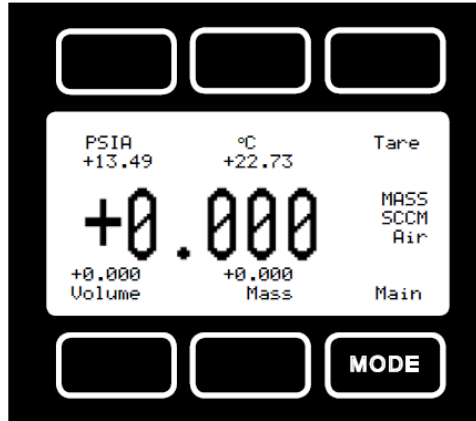
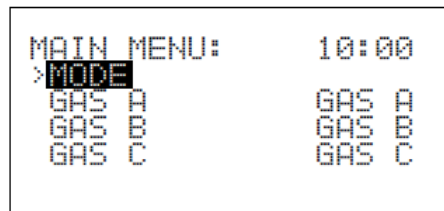

Figure 1 Alicat Mode Screen

Zero the unit near the expected operating pressure by positively blocking the flow downstream of the flow meter prior to pushing the "Tare" button. Zeroing the unit while there is any flow will directly affect the accuracy by providing a false zero point. If in doubt about whether a zero flow condition exists, remove the unit from the line and positively block both ports before pressing the tare button. If the unit reads a significant negative value when removed from the line and blocked, it is a good indication that it was given a false zero. It is better to zero the unit at atmospheric pressure and a confirmed no flow conditions than to give it a false zero under line pressure.

When the Alicat tare is stable, remove the caps and connect it to the 146C calibrator to be certified observing correct flow direction.

- Place 146C in "Service" mode:
Start at the 146C Main Menu, use the ↑ or ↓ pushbuttons to move the menu cursor ">" up or down and select **Mode** <ENTER>



Main Menu Screen

Using the Service Mode screen:
To change modes, use the ↑ or ↓ pushbuttons
To set the mode, press <ENTER>
To return to the Main Menu, press **Menu**.

```
MODE:          SERVICE
SET TO REMOTE?
```

Mode Screen

* **Note:** If this is day 1 of the certification procedure, load the default parameters and enter pressure and temperature.

* Load Default Parameters – lets you reset Model 146C to its factory settings. Thermo Environmental recommends that you do this only when a new processor is installed. It has been found that this must be done prior to adjusting zero and or span of a MFC. It can be reset at every certification, but is not absolutely necessary.

Note: If this is day 2 of the certification procedure, **DO NOT** load the default parameters, enter pressure and temperature.

Start at the 146C Main Menu, use the ↑ or ↓ pushbuttons to move the menu cursor ">" up or down and select > **Load Default Params** <ENTER>

```
MAIN MENU:      10:00
>MODE
GAS A           GAS A
GAS B           GAS B
GAS C           GAS C

OZONATOR
PERMEATION OVEN
PROGRAM
ALARMS
INSTRUMENT CONTROLS
DIAGNOSTICS
```

Note: Items shown below are only available in Service mode.

```
LOAD DEFAULT PARAMS
FLOW CONTROL FSCALES
ENTER PRES AND TEMP
ZERO AIR FLOW CAL
GAS FLOW CAL SOL
GAS FLOW CAL
EXTERNAL SOLENOIDS
A/D FREQUENCY
SET TEST DISPLAY
```

Main Menu Screen

```
LOAD DEFAULT PARAMS?  
ARE YOU SURE?  
HONEST?
```

Load Default Parameters with prompts

- Check the Flow Control FSCALES for proper range
Start at the 146C Main Menu, use the ↑ or ↓ pushbuttons to move the menu cursor ">" up or down and select **Flow Contrl Fscals** <ENTER>

```
MAIN MENU:      10:00  
>MODE  
GAS A           GAS A  
GAS B           GAS B  
GAS C           GAS C
```

```
OZONATOR  
PERMEATION OVEN  
PROGRAM  
ALARMS  
INSTRUMENT CONTROLS  
DIAGNOSTICS
```

Note: Items shown below are only available in Service mode.

```
LOAD DEFAULT PARAMS  
FLOW CONTROL FSCALES  
ENTER PRES AND TEMP  
ZERO AIR FLOW CAL  
GAS FLOW CAL SOL  
GAS FLOW CAL  
EXTERNAL SOLENOIDS  
A/D FREQUENCY  
SET TEST DISPLAY
```

Main Menu Screen

```
FLOW CONTRL FSCALES:  
>ZERO AIR SLM 20.00  
GAS SCCM 50.00
```

Flow Control Fullscale Menu

- Enter **Pressure** and **Temperature**
Note: The **Zero Air Drive** screen cannot be accessed without entering the ambient pressure and/or temperature.

Start at the 146C Main Menu, use the ↑ or ↓ pushbuttons to move the menu cursor ">" up or down and select **ENTER PRES AND TEMP**, <ENTER>

```
MAIN MENU:      10:00
>MODE
GAS A           GAS A
GAS B           GAS B
GAS C           GAS C
```

```
OZONATOR
PERMEATION OVEN
PROGRAM
ALARMS
INSTRUMENT CONTROLS
DIAGNOSTICS
```

Note: Items shown below are only available in Service mode.

```
LOAD DEFAULT PARAMS
FLOW CONTROL FSCALES
ENTER PRES AND TEMP
ZERO AIR FLOW CAL
GAS FLOW CAL SOL
GAS FLOW CAL
EXTERNAL SOLENOIDS
```

Main Menu Screen

Enter the pressure (760) and temperature (25) into the 146C <ENTER>, the 146C will update the **REL VOLUME** to reflect the changes, record these numbers in the 146C certification spread sheet.

```
ENTER PRES AND TEMP:
PRES 760.0 TEMP 25.0
ENTER?

REL VOLUME      1.000
```

Pressure and Temperature Screen

Start at the 146C Main Menu, use the \uparrow or \downarrow pushbuttons to move the menu cursor ">" up or down and select **ZERO AIR FLOW CAL** <ENTER> select **5% FS SLM** <ENTER>

```
MAIN MENU:      10:00
>MODE
GAS A          GAS A
GAS B          GAS B
GAS C          GAS C
```

```
OZONATOR
PERMEATION OVEN
PROGRAM
ALARMS
INSTRUMENT CONTROLS
DIAGNOSTICS
```

Note: Items shown below are only available in Service mode.

```
LOAD DEFAULT PARAMS
FLOW CONTROL FS CALES
ENTER PRES AND TEMP
ZERO AIR FLOW CAL
GAS FLOW CAL SOL
GAS FLOW CAL
EXTERNAL SOLENOIDS
A/D FREQUENCY
SET TEST DISPLAY
```

Main Menu Screen

```
ZERO AIR FLOW CAL:
> 5% FS SLM 0.500
 20% FS SLM 2.000
 35% FS SLM 3.500
```

```
50% FS SLM 5.000
65% FS SLM 6.500
80% FS SLM 8.000
95% FS SLM 9.500
```

Zero-air Flow Calibration Menu

```
ZERO AIR DRIVE 5%:
STD FLOW SLM 00.500
VOL FLOW LM 00.500
ENTER?
```

DO NOT PRESS "ENTER" —

Zero-air Drive Screen

Allow an equilibration time long enough to stabilize the Alicat and 146C MFC (~1hour). The flows can be monitored via the PDL hyper-terminal screen.

Data logger Login

- Double click "PDL"
- Open PDL
- Highlight PDL and type 2 letter data logger site code and AQM, (e.g.) "LR AQM" (located on front of data logger, may have to hit {ESC} a couple of times before typing)
- Select: "L" Login <ENTER>
- Type password: **XXXXXXXXXX** (not case sensitive), this brings up Home Menu
- Select: "C" Configuration Menu <ENTER>
- Select: "C" Configure Calibrations <ENTER>
- Select: "S" Start a Calibration Program <ENTER>
- Select: "5%ACERT" <ENTER>

The 5% ACERT runs for 40 minutes, 15 minutes equilibration + 5 x 5 minute blocks.

- **ESC, ESC, ESC** to Home Menu
- Select: "D" Real-Time Display Menu <ENTER>
- Select: "C" Continuous Avg Report <ENTER>
- Start Continuous Report (for all five (5) channels) <ENTER>

```
ESC 8832 v3.00 ID:LR      Continuous Avg Report Setup      03/05/10 09:15:47
Average Interval          : 1m
Show Channels              : 146GFW,146AFW,AC50/100,AC10/20,ACKAVG

# of Flags to Report      : 02
Use Decimal Positioner?   : Y
Start Continuous Report
```

Monitor the 146AFW (146C gas flow averages) and AC10/20 (Alicat gas flow averages)

TIME	146GFW	146AFW	AC50/100	AC10/20	ACKAVG
03/05 12:30	0.0	1100.0	1.100	1100.0 <C	1100.0 <B
03/05 12:31	0.0	1100.0	1.100	1100.0 <C	1100.0 <B
03/05 12:32	0.0	1100.0	1.100	1100.0 <C	1100.0 <B
03/05 12:33	0.0	1100.0	1.100	1100.0 <C	1100.0 <B
03/05 12:34	0.0	1100.0	1.100	1100.0 <C	1100.0 <B
03/05 12:35	0.0	1100.0	1.100	1100.0 <C	1100.0 <B
03/05 12:36	0.0	1100.0	1.100	1100.0 <C	1100.0 <B
03/05 12:37	0.0	1100.0	1.100	1100.0 <C	1100.0 <B
03/05 12:38	0.0	1100.0	1.100	1100.0 <C	1100.0 <B
03/05 12:39	0.0	1100.0	1.100	1100.0 <C	1100.0 <B
03/05 12:40	0.0	1100.0	1.100	1100.0 <C	1100.0 <B
03/05 12:41	0.0	1100.0	1.100	1100.0 <C	1100.0 <B
03/05 12:42	0.0	1100.0	1.100	1100.0 <C	1100.0 <B
03/05 12:43	0.0	1100.0	1.100	1100.0 <C	1100.0 <B
03/05 12:44	0.0	1100.0	1.100	1100.0 <C	1100.0 <B
03/05 12:45	0.0	1100.0	1.100	1100.0 <C	1100.0 <B
03/05 12:46	0.0	1100.0	1.100	1100.0 <C	1100.0 <B

ESC or SPACE to exit

The 5% ACERT status can also be monitored by:

- ESC, ESC, ESC to Home Menu
- Select: "S" Start a Calibration Program <ENTER>
- Select: "C" Continuous Avg Report <ENTER>

Sequence	Type	Status
100CCFC	Auto	Runs at 12/12/12 00:00:00
10LPMFC	Auto	Runs at 12/12/12 00:00:00
20%ACERT	User	INACTIVE
20%GCERT	User	INACTIVE
20LPMFC	Auto	Runs at 12/12/12 00:00:00
35%ACERT	User	INACTIVE
35%GCERT	User	INACTIVE
5%ACERT	User	SKAIRK1 (18m 50s left) ←
5%GCERT	User	INACTIVE
50%ACERT	User	INACTIVE
50%GCERT	User	INACTIVE
50CCMFC	Auto	Runs at 12/12/12 00:00:00
65%ACERT	User	INACTIVE
65%GCERT	User	INACTIVE
80%ACERT	User	INACTIVE
80%GCERT	User	INACTIVE
95%ACERT	User	INACTIVE
95%GCERT	User	INACTIVE

--- ESC or SPACE to exit ---

When the 5%ACERT is finished, the "<C" appearing next to AC10/20 1 minute averages and the "<B" next to ACKAVG 1 minute averages will disappear.

TIME	146GFW	146AFW	AC50/100	AC10/20	ACKAVG
03/05 12:30	0.0	1100.0	1.100	1100.0<C	1100.0<B
03/05 12:31	0.0	1100.0	1.100	1100.0<C	1100.0<B
03/05 12:32	0.0	1100.0	1.100	1100.0<C	1100.0<B
03/05 12:33	0.0	1100.0	1.100	1100.0<C	1100.0<B
03/05 12:34	0.0	1100.0	1.100	1100.0<C	1100.0<B
03/05 12:35	0.0	1100.0	1.100	1100.0<C	1100.0<B
03/05 12:36	0.0	1100.0	1.100	1100.0<C	1100.0<B
03/05 12:37	0.0	1100.0	1.100	1100.0<C	1100.0<B
03/05 12:38	0.0	1100.0	1.100	1100.0<C	1100.0<B
03/05 12:39	0.0	1100.0	1.100	1100.0<C	1100.0<B
03/05 12:40	0.0	1100.0	1.100	1100.0<C	1100.0<B
03/05 12:41	0.0	1100.0	1.100	1100.0<C	1100.0<B
03/05 12:42	0.0	1100.0	1.100	1100.0<C	1100.0<B
03/05 12:43	0.0	1100.0	1.100	1100.0<C	1100.0<B
03/05 12:44	0.0	1100.0	1.100	1100.0<C	1100.0<B
03/05 12:45	0.0	1100.0	1.100	1100.0<C	1100.0<B
03/05 12:46	0.0	1100.0	1.100	1100.0	1100.0

ESC or SPACE to exit

a. After the "<B" disappears, enter **ACKAVG** flow into the 146C screen "**VOL FLOW LM**" using the ← → and ↑↓ arrows, <ENTER> (all flows are in sccm and need to be converted to Liters Minute (LM), ex. 1100/1000= 1.100)

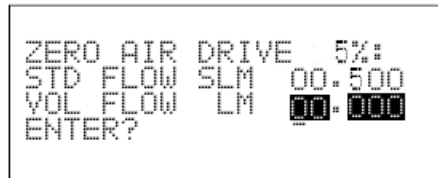

Zero-air Drive Screen

- b. The 1 minute ACKAVG number is the average of 5, 5 minute consecutive blocks.
- ESC, ESC, ESC to Home Menu
 - Select: "C" Configuration Menu <ENTER>
 - Select: "C" Configure Calibrations <ENTER>
 - Select: "K" Configure Math constants <ENTER>

ESC 8832 v3.00 ID:LR		Set Math Pack Constants		03/05/10 10:20:55	
Constant K1 =			1092.6		
Constant K2 =			1099.8		
Constant K3 =			1100		
Constant K4 =			1100.3		
Constant K5 =			1103.9		
Constant K6 =			1		
Constant K7 =			1		
Constant K8 =			1		
Constant K9 =			1		
Constant K10 =			1		

Copy/paste or type the K1-K5 math constants into the 146C certification excel spreadsheet ("20 LPM Air or 10 LPM Air" tab). These constants are overwritten six (6) more times in the 146C certification.

Start at the 146C Main Menu, press the ↓ pushbutton to move the menu cursor ">" down to select the next **Drive Level, 20% FS SLM 2.000** <ENTER>.

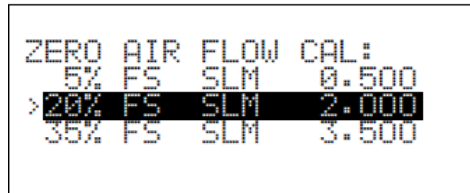

Zero-air Flow Calibration Menu

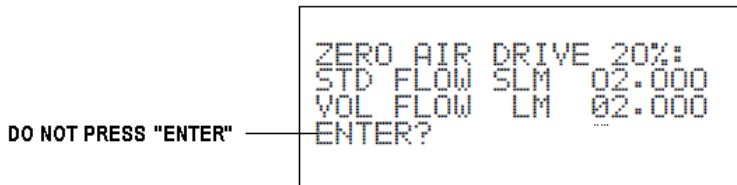

Zero-air Drive Screen

Start 20% ACERT

- ESC, ESC, ESC to Home Menu
- Select: "C" Configuration Menu <ENTER>
- Select: "C" Configure Calibrations <ENTER>
- Select: "S" Start a Calibration Program <ENTER>
- Select: "20%ACERT" <ENTER>

The 20% ACERT runs for 40 minutes (15 minutes equilibration + 5 x 5 minute blocks). To check progress of 20% ACERT:

- ESC, ESC, ESC to Home Menu
- Select: "D" Real-Time Display Menu <ENTER>
- Select: "C" Continuous Avg Report <ENTER>
- Start Continuous Report (for all five (5) channels) <ENTER>

```

ESC 8832 v3.00 ID:LR      Continuous Avg Report Setup      03/05/10 09:15:47
Average Interval          : 1m
Show Channels             : 146GFW,146AFW,AC50/100,AC10/20,ACKAVG

# of Flags to Report      : 02
Use Decimal Positioner?   : Y
Start Continuous Report

```

Monitor the 146AFW (146C gas flow averages) and AC10/20 (Alicat gas flow averages)

TIME	146GFW	146AFW	AC50/100	AC10/20	ACKAVG
03/05 12:30	0.0	4100.0	4.100	4100.0 <C	4100.0 <B
03/05 12:31	0.0	4100.0	4.100	4100.0 <C	4100.0 <B
03/05 12:32	0.0	4100.0	4.100	4100.0 <C	4100.0 <B
03/05 12:33	0.0	4100.0	4.100	4100.0 <C	4100.0 <B
03/05 12:34	0.0	4100.0	4.100	4100.0 <C	4100.0 <B
03/05 12:35	0.0	4100.0	4.100	4100.0 <C	4100.0 <B
03/05 12:36	0.0	4100.0	4.100	4100.0 <C	4100.0 <B
03/05 12:37	0.0	4100.0	4.100	4100.0 <C	4100.0 <B
03/05 12:38	0.0	4100.0	4.100	4100.0 <C	4100.0 <B
03/05 12:39	0.0	4100.0	4.100	4100.0 <C	4100.0 <B
03/05 12:40	0.0	4100.0	4.100	4100.0 <C	4100.0 <B
03/05 12:41	0.0	4100.0	4.100	4100.0 <C	4100.0 <B
03/05 12:42	0.0	4100.0	4.100	4100.0 <C	4100.0 <B
03/05 12:43	0.0	4100.0	4.100	4100.0 <C	4100.0 <B
03/05 12:44	0.0	4100.0	4.100	4100.0 <C	4100.0 <B
03/05 12:45	0.0	4100.0	4.100	4100.0 <C	4100.0 <B
03/05 12:46	0.0	4100.0	4.100	4100.0 <C	4100.0 <B

ESC or SPACE to exit

When the 20%ACERT is finished, the "<C" appearing next to AC10/20 1 minute averages and the "<B" next to ACKAVG 1 minute averages will disappear.

TIME	1466FW	146AFW	AC50/100	AC10/20	ACKAVG
03/05 12:30	0.0	4100.0	4.100	4100.0 <C	4100.0 <B
03/05 12:31	0.0	4100.0	4.100	4100.0 <C	4100.0 <B
03/05 12:32	0.0	4100.0	4.100	4100.0 <C	4100.0 <B
03/05 12:33	0.0	4100.0	4.100	4100.0 <C	4100.0 <B
03/05 12:34	0.0	4100.0	4.100	4100.0 <C	4100.0 <B
03/05 12:35	0.0	4100.0	4.100	4100.0 <C	4100.0 <B
03/05 12:36	0.0	4100.0	4.100	4100.0 <C	4100.0 <B
03/05 12:37	0.0	4100.0	4.100	4100.0 <C	4100.0 <B
03/05 12:38	0.0	4100.0	4.100	4100.0 <C	4100.0 <B
03/05 12:39	0.0	4100.0	4.100	4100.0 <C	4100.0 <B
03/05 12:40	0.0	4100.0	4.100	4100.0 <C	4100.0 <B
03/05 12:41	0.0	4100.0	4.100	4100.0 <C	4100.0 <B
03/05 12:42	0.0	4100.0	4.100	4100.0 <C	4100.0 <B
03/05 12:43	0.0	4100.0	4.100	4100.0 <C	4100.0 <B
03/05 12:44	0.0	4100.0	4.100	4100.0 <C	4100.0 <B
03/05 12:45	0.0	4100.0	4.100	4100.0 <C	4100.0 <B
03/05 12:46	0.0	4100.0	4.100	4100.0	4100.0

- a. After the "<B" disappears, enter **ACKAVG** flow into the 146C screen "**VOL FLOW LM**" using the ← → and ↑↓ arrows, <ENTER> (all flows are in scfm and need to convert to LM, ex. 4100/1000 = 4.100)

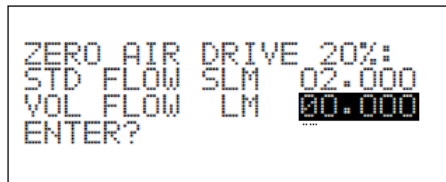

Zero Air Drive Screen

- b. The 1 minute ACKAVG number is the average of 5, 5 minute consecutive blocks.
- ESC, ESC, ESC to Home Menu
 - Select: "**C**" Configuration Menu <ENTER>
 - Select: "**C**" Configure Calibrations <ENTER>
 - Select: "**K**" Configure Math constants <ENTER>

ESC 8832 v3.00 ID:LR		Set Math Pack Constants	03/05/10 10:20:55
Constant K1 =		4092.6	
Constant K2 =		4099.8	
Constant K3 =		4100	
Constant K4 =		4100.3	
Constant K5 =		4103.9	
Constant K6 =		1	
Constant K7 =		1	
Constant K8 =		1	
Constant K9 =		1	
Constant K10 =		1	
Constant K11 =		1	
Constant K12 =		1	
Constant K13 =		1	
Constant K14 =		1	

Copy/paste or type the K1-K5 math constants into the 146C certification excel spreadsheet ("20 LPM Air or 10 LPM Air" tab). These constants are overwritten five (5) more times in the 146C certification.

Repeat steps for the remaining certification points.

2.3.4.6 146C Zero Air Verification

Once programmed, the verification is intended to run un-attended. Programming should include a 2-4 hour equilibration time. Air verification is two (2) hours long. The verification monitors the actual flow versus the flow settings for five points (5%, 25%, 50%, 75% and 95%) equally spaced flows along the range of the device. The $\Delta\%$ of 146AFW averages and AC10/20 averages should fall within:

	50 sccm	100 sccm	10 slpm	20 slpm
5%	$\leq (\pm) 6.00\%$	$\leq (\pm) 5.00\%$	$\leq (\pm) 4.00\%$	$\leq (\pm) 3.00\%$
25%	$\leq (\pm) 1.00\%$	$\leq (\pm) 1.00\%$	$\leq (\pm) 1.00\%$	$\leq (\pm) 1.00\%$
50%	$\leq (\pm) 1.00\%$	$\leq (\pm) 1.00\%$	$\leq (\pm) 1.00\%$	$\leq (\pm) 1.00\%$
75%	$\leq (\pm) 1.00\%$	$\leq (\pm) 1.00\%$	$\leq (\pm) 1.00\%$	$\leq (\pm) 1.00\%$
95%	$\leq (\pm) 1.00\%$	$\leq (\pm) 1.00\%$	$\leq (\pm) 1.00\%$	$\leq (\pm) 1.00\%$

sccm = standard cubic centimeters per minute

slpm = standard liters per minute

Disconnect the Alicat from the 146C calibrator, cap both ends and re-zero the Alicat.

Tare - Pushing the labeled "Tare" button for about 5 seconds in the upper right hand corner tares the flow meter and provides it with a reference point for zero flow. **Note:** It is critical to have a stable tare before starting the air verification procedure. This is a simple but important step in obtaining accurate measurements.

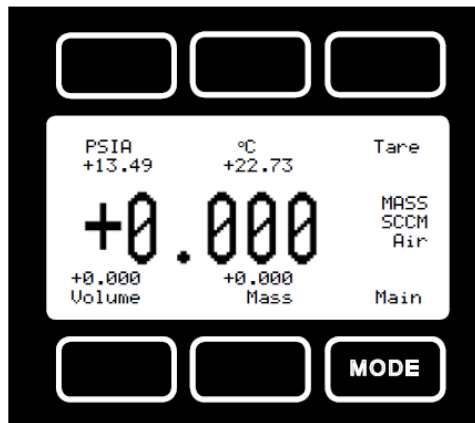

Alicat Mode Screen

- ESC, ESC, ESC to Home Menu

- Select: "C" Configuration Menu <ENTER>
- Select: "C" Configure Calibrations <ENTER>
- Select: "S" Start a Calibration Program <ENTER>
- Select: "20LPMFC" <ENTER>
- ESC, ESC, ESC to Home Menu
- Select: "D" Real-Time Display Menu <ENTER>
- Select: "C" Continuous Avg Report <ENTER>
- Start Continuous Report (for all five (5) channels) <ENTER>

```

ESC 8832 v3.00 ID:LR      Continuous Avg Report Setup      03/05/10 09:15:47
Average Interval          : 1m
Show Channels             : 146GFW,146AFW,AC50/100,AC10/20,ACKAVG

# of Flags to Report      : 02
Use Decimal Positioner?   : Y
Start Continuous Report

```

Monitor the channels while taring the Alicat.

TIME	146GFW	146AFW	AC50/100	AC10/20	ACKAVG
03/05 12:30	0.0	0.0	0.0	0.0	0.0
03/05 12:31	0.0	0.0	0.0	0.0	0.0
03/05 12:32	0.0	0.0	0.0	0.0	0.0
03/05 12:33	0.0	0.0	0.0	0.0	0.0
03/05 12:34	0.0	0.0	0.0	0.0	0.0
03/05 12:35	0.0	0.0	0.0	0.0	0.0
03/05 12:36	0.0	0.0	0.0	0.0	0.0
03/05 12:37	0.0	0.0	0.0	0.0	0.0
03/05 12:38	0.0	0.0	0.0	0.0	0.0
03/05 12:39	0.0	0.0	0.0	0.0	0.0
03/05 12:40	0.0	0.0	0.0	0.0	0.0
03/05 12:41	0.0	0.0	0.0	0.0	0.0
03/05 12:42	0.0	0.0	0.0	0.0	0.0
03/05 12:43	0.0	0.0	0.0	0.0	0.0
03/05 12:44	0.0	0.0	0.0	0.0	0.0
03/05 12:45	0.0	0.0	0.0	0.0	0.0

When the Alicat tare is stable, remove the caps and re-connect it to the 146C calibrator to be verified.

146C must be in "Remote" mode:

To display the Mode screen, start at the 146C **Main Menu** and select **Mode**.

Using the Service Mode screen:

To change modes, use the ↑ or ↓ pushbuttons

To set the mode, press <ENTER>

```
MODE:          SERVICE
SET TO REMOTE?
```

Mode Screen

- ESC, ESC, ESC to Home Menu
- Select: "C" Configuration Menu <ENTER>
- Select: "C" Configure Calibrations <ENTER>
- Select: "S" Start a Calibration Program <ENTER>
- Select: "20LPMFC", when time clock reaches :03, press <ENTER>

```
ESC 8832 v3.00 ID:LR Choose List (Enter to Select) 03/05/10 09:18:03
100CCFC          95%ACERT
10LPMFC          95%GCERT
20%ACERT
20%GCERT
20LPMFC
35%ACERT
35%GCERT
5%ACERT
5%GCERT
50%ACERT
50%GCERT
50CCMFC
65%ACERT
65%GCERT
```

K Factors 6-10 (146 Flow) with durations:

	Verification Point:
K6: 40 minutes, average last 5x1 minute averages	5%
K7: 20 minutes, average last 5x1 minute averages	25%
K8: 20 minutes, average last 5x1 minute averages	50%
K9: 20 minutes, average last 5x1 minute averages	75%
K10: 20 minutes, average last 5x1 minute averages	95%

K Factors 11-15 (Alicat Flow) with durations:

	Verification Point:
K11: 40 minutes, average last 5x1 minute averages	5%
K12: 20 minutes, average last 5x1 minute averages	25%
K13: 20 minutes, average last 5x1 minute averages	50%
K14: 20 minutes, average last 5x1 minute averages	75%
K15: 20 minutes, average last 5x1 minute averages	95%

To view verification results:

- ESC, ESC, ESC to Home Menu
- Select: "C" Configuration Menu <ENTER>
- Select: "C" Configure Calibrations <ENTER>

- Select: "**K**" Configure Math constants <ENTER>

ESC 8832 v3.00 ID:LR		Set Math Pack Constants	
Constant K1 =		1	
Constant K2 =		1	
Constant K3 =		1	
Constant K4 =		1	
Constant K5 =		1	
Constant K6 =		1100	} 146AFW
Constant K7 =		4101	
Constant K8 =		10100	
Constant K9 =		15100	
Constant K10 =		19100	
Constant K11 =		1100	} AC10/20
Constant K12 =		4100	
Constant K13 =		10100	
Constant K14 =		15100	
Constant K15 =		19100	
Constant K16 =		1	

Copy/paste or type the K6-K15 math constants into the 146C certification excel spreadsheet ("Air Verifications" tab).

If difficulty is encountered due to a malfunction of the flow controller, contact Thermo Environmental Instruments

2.3.4.7 Zero Air Data Collection

All minute averages and calibration data are automatically polled every 24 hours. This is done utilizing the E-DAS Autopoll feature. Any minute average or calibration report can be examined using the "Reports" tab on the E-DAS Ambient menu. Data is stored in C:\EDASSCR\146C verify and certify 02-25-10\.

To view zero air data, open E-DAS Ambient menu. Click on "**Reports**" tab.

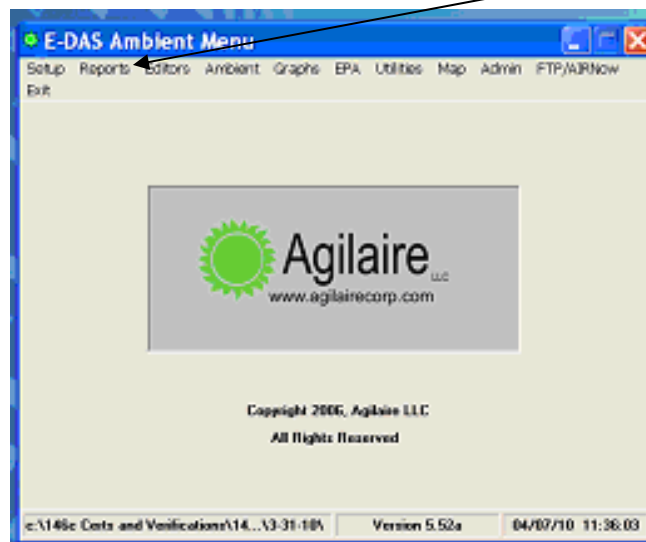

On drop down, select "**Calibration Report**".

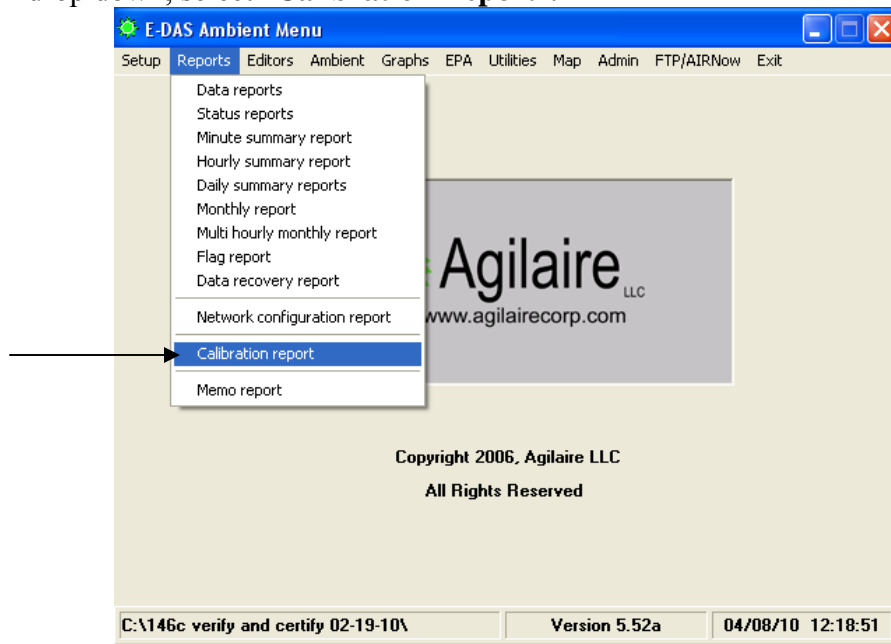

Select the "**ACERT**" certification points and range of dates, click "**OK**"

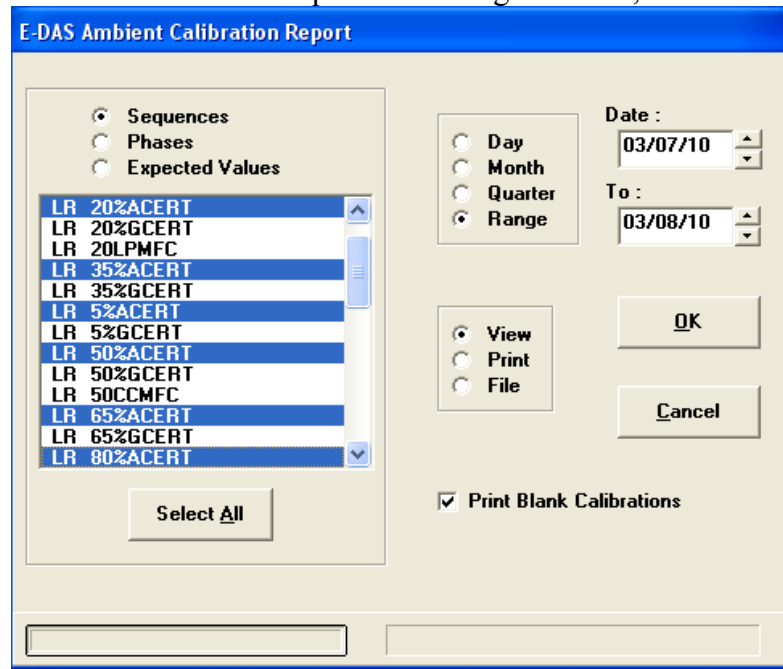

02/23/10	LR	20%ACERT	20%AIRK1	AC10/20	12:32	12:52	3908	0
			20%AIRK2	AC10/20	12:32	12:57	3908	0
			20%AIRK3	AC10/20	12:32	13:02	3901	0
			20%AIRK4	AC10/20	12:32	13:07	3900	0
			20%AIRK5	AC10/20	12:32	13:12	3900	0
	35%ACERT		35%AIRK1	AC10/20	13:15	13:35	6939	0
			35%AIRK2	AC10/20	13:15	13:40	6939	0
			35%AIRK3	AC10/20	13:15	13:45	6939	0
			35%AIRK4	AC10/20	13:15	13:50	6940	0
			35%AIRK5	AC10/20	13:15	13:55	6939	0
	5%ACERT		5%AIRK1	AC10/20	11:49	12:09	891	0
			5%AIRK2	AC10/20	11:49	12:14	890	0
			5%AIRK3	AC10/20	11:49	12:19	885	0
			5%AIRK4	AC10/20	11:49	12:24	880	0
			5%AIRK5	AC10/20	11:49	12:29	875	0
	50%ACERT		50%AIRK1	AC10/20	14:02	14:22	9959	0
			50%AIRK2	AC10/20	14:02	14:27	9956	0
			50%AIRK3	AC10/20	14:02	14:32	9956	0
			50%AIRK4	AC10/20	14:02	14:37	9958	0
			50%AIRK5	AC10/20	14:02	14:42	9960	0
	65%ACERT		65%AIRK1	AC10/20				
			65%AIRK2	AC10/20				

Zero Air Certification Points

To check zero air verification, select the "20LPMFC" and range of dates, click "OK"

E-DAS Ambient Calibration Report

Sequences
 Phases
 Expected Values

Day
 Month
 Quarter
 Range

Date : 02/07/10

To : 02/20/10

View
 Print
 File

Print Blank Calibrations

OK

Cancel

Select All

Date	Sequence Id	Sequence Name	Phase Name	Param Name	Start Time	End Time	Calibration Value	Expected Value	Drift (%Span)
02/07/10	LR	20LPMFC	5%RN20	146AFW	11:32	12:12	1001	1000	
				AC10/20	11:32	12:12	1002	1000	
			25%RN20	146AFW	11:32	12:33	5001	5000	
				AC10/20	11:32	12:33	5002	5000	
			50%RN20	146AFW	11:32	12:54	10001	10000	
				AC10/20	11:32	12:54	10002	10000	
			75%RN20	146AFW	11:32	13:16	15002	15000	
				AC10/20	11:32	13:16	15002	15000	
			95%RN20	146AFW	11:32	13:37	19002	19000	
				AC10/20	11:32	13:37	19002	19000	

Zero Air Verification Points

2.3.4.8 146C Gas Certification

The Alicat 50 M-SCCM-D is used to certify the 50 SCCM gas channels (NCore) and a 100 M-SCCM-D is used to certify the 100 SCCM gas channels (non NCore). The 146C certification is a two day procedure. Whichever mass flow controller is done first air or gas, the certification will include a **146C Verification**.

The 146C adjusts its outputs using an algorithm derived from the pressure and temperature compensated volumetric flows.

The term certification means determining the actual flow versus the flow settings for seven points (5%, 20%, 35%, 50%, 65%, 80%, and 95%) equally spaced flows along the range of the device.

- The entire Gas Certification takes a minimum of 4 hours and 40 minutes.
- A seven-point certification is performed and documented in the 146C certification excel spreadsheet. The 20% to 95% points should fall within $\pm 2\%$ of actual flow.

Certification gas used for 50/100SCCM gas mass flow controllers is Air.

The following provides a step-by-step procedure for certifying the gas mass flow controller of the 146C calibrator:

- a. Select the appropriate Alicat for the certification.
 - b. Connect clean, zero air (30 psi) to "GAS A" inlet port, cap "Vent", "GAS B", and "C" ports (see pg. 54, 146C Rear View). Set pressure to 30 psi. **Note:** Make sure air is 30 psi during certification.
- Connect power to the Alicat and configure the Alicat to data logger, serial port #2. Connect the 146C serial port to the data logger serial port #3. Cap both ends of the Alicat and let the instrument stabilize (~ 1hour).

- **Tare** - Perform an initial flow tare of the zero air Alicat. Pushing the labeled "**Tare**" button for about 5 seconds in the upper right hand corner (Figure 1) tares the flow meter and provides it with a reference point for zero flow. **Note:** It is critical to have a stable tare before starting the air certification procedure. This is a simple but important step in obtaining accurate measurements.

It is good practice to "zero" the flow meter each time it is powered up. If the flow reading varies significantly from zero after an initial tare (**Zero no flow criteria:** 50/100SCCM = .3sccm), give the unit a minute or so to warm up and re-zero it. May have to hit "TARE" several times.

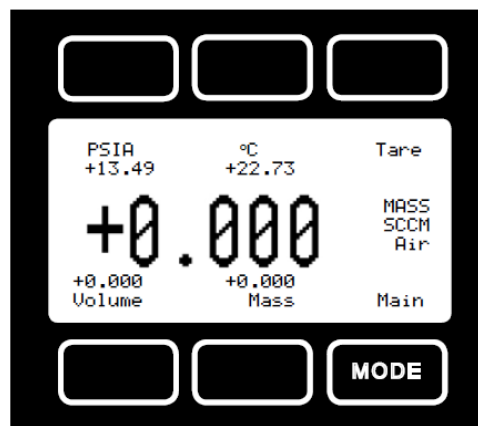

Figure 1 Alicat Mode Screen

Zero the unit near the expected operating pressure by positively blocking the flow downstream of the flow meter prior to pushing the "Tare" button. Zeroing the unit while there is any flow will directly affect the accuracy by providing a false zero point. If in doubt about whether a zero flow condition exists, remove the unit from the line and positively block both ports before pressing the "Tare" button. If the unit reads a significant negative value when removed from the line and blocked, it is a good indication that it was given a false zero. It is better to zero the unit at atmospheric pressure and a confirmed no flow conditions than to give it a false zero under line pressure.

When the Alicat tare is stable, remove the caps and connect it to the 146C calibrator to be certified.

- Place 146C in "**Service**" mode:
Start at the 146C Main Menu, use the ↑ or ↓ pushbuttons to move the cursor up or down and select **Mode** <ENTER>

```
MAIN MENU:      10:00
>MODE
GAS A          GAS A
GAS B          GAS B
GAS C          GAS C
```

Main Menu Screen

Using the Service Mode screen:
To change modes, use the ↑ or ↓ pushbuttons
To set the mode, press <ENTER>
To return to the Main Menu, press **Menu**.

```
MODE:          SERVICE
SET TO REMOTE?
```

Mode Screen

- * **Note:** If this day 1 of the 146C certification, load default parameters.
- * Load Default Parameters – lets you reset Model 146C to its factory settings. Thermo Environmental recommends that you do this only when a new processor is installed. It has been found that this must be done prior to adjusting zero and or span of a MFC. It can be reset at every certification, but is not absolutely necessary.

Note: If this day 2 of the 146C certification, **DO NOT** load default parameters (they were previously loaded).

Start at the 146C Main Menu, use the ↑ or ↓ pushbuttons to move the menu cursor ">" up or down and select > **Load Default Params** <ENTER>

```
MAIN MENU:      10:00  
>MODE  
GAS A          GAS A  
GAS B          GAS B  
GAS C          GAS C
```

```
OZONATOR  
PERMEATION OVEN  
PROGRAM  
ALARMS  
INSTRUMENT CONTROLS  
DIAGNOSTICS
```

Note: Items shown below are only available in Service mode.

```
LOAD DEFAULT PARAMS  
FLOW CONTROL FSCALES  
ENTER PRES AND TEMP  
ZERO AIR FLOW CAL  
GAS FLOW CAL SOL  
GAS FLOW CAL  
EXTERNAL SOLENOIDS  
A/D FREQUENCY  
SET TEST DISPLAY
```

Main Menu Screen

```
LOAD DEFAULT PARAMS?  
ARE YOU SURE?  
HONEST?
```

Load Default Parameters with prompts

- Check the Flow Control FSCALES for proper range
Start at the 146C Main Menu, use the ↑ or ↓ pushbuttons to move the cursor up or down and select **Flow Contrl Fscals** <ENTER>, select **GAS SCCM** <ENTER>

```
MAIN MENU:      10:00  
>MODE  
GAS A          GAS A  
GAS B          GAS B  
GAS C          GAS C
```

```
OZONATOR  
PERMEATION OVEN  
PROGRAM  
ALARMS  
INSTRUMENT CONTROLS  
DIAGNOSTICS
```

Note: Items shown below are only available in Service mode.

```
LOAD DEFAULT PARAMS  
FLOW CONTROL FSCALES  
ENTER PRES AND TEMP  
ZERO AIR FLOW CAL  
GAS FLOW CAL SOL  
GAS FLOW CAL  
EXTERNAL SOLENOIDS  
A/D FREQUENCY  
SET TEST DISPLAY
```

Main Menu Screen

```
FLOW CONTRL FSCALES:  
ZERO AIR SLM  20.00  
>GAS SCCM  50.00
```

Flow Control Fullscale Menu

- Enter **Pressure** and **Temperature**

Note: The **Zero Air Drive** screen cannot be accessed without entering the ambient pressure and/or temperature.

Start at the 146C Main Menu, use the ↑ or ↓ pushbuttons to move the menu cursor ">" up or down and select **ENTER PRES AND TEMP**, <ENTER>

```
MAIN MENU:      10:00
>MODE
GAS A          GAS A
GAS B          GAS B
GAS C          GAS C
```

```
OZONATOR
PERMEATION OVEN
PROGRAM
ALARMS
INSTRUMENT CONTROLS
DIAGNOSTICS
```

Note: Items shown below are only available in Service mode.

```
LOAD DEFAULT PARAMS
FLOW CONTROL FSCALES
ENTER PRES AND TEMP
ZERO AIR FLOW CAL
GAS FLOW CAL SOL
GAS FLOW CAL
EXTERNAL SOLENOIDS
A/D FREQUENCY
SET TEST DISPLAY
```

Main Menu Screen

Enter the pressure (760) and temperature (25) into the 146C <ENTER>, the 146C will update the **REL VOLUME** to reflect the changes, record these numbers in the 146C certification spread sheet.

```
ENTER PRES AND TEMP:
PRES 760.0 TEMP 25.0
ENTER?

REL VOLUME      1.000
```

Pressure and Temperature Screen

Start at the 146C Main Menu, use the \uparrow or \downarrow pushbuttons to move the menu cursor ">" up or down and select **GAS FLOW CAL SOL** <ENTER>, select **A** solenoid <ENTER>, select **5% FS SCCM** <ENTER>

```
GAS FLOW CAL:
SOLENOID      A
SET TO       B
ENTER?       -
```

Gas Flow Cal Screen

Start at the 146C Main Menu, use the \uparrow or \downarrow pushbuttons to move the menu cursor ">" up or down, and select **GAS FLOW CAL** <ENTER>, select **5% FS SCCM** <ENTER>

```
GAS AIR FLOW CAL:
> 5% FS SCCM 0.500
 20% FS SCCM 2.000
 35% FS SCCM 3.500
```

```
50% FS SCCM 5.000
65% FS SCCM 6.500
80% FS SCCM 8.000
95% FS SCCM 9.500
```

Gas Flow Calibration Menu

DO NOT PRESS "ENTER" —

```
GAS DRIVE 5%:
STD FLOW SCCM 00.500
VOL FLOW CCM 00.500
ENTER?
```

Gas Drive Screen

Allow an equilibration time long enough to stabilize the Alicat and 146C MFC (~1hour). The flows can be monitored via the PDL hyper-terminal screen.

Data logger Login:

- Double click "PDL"
- Open PDL
- Highlight PDL and type 2 letter data logger site code and AQM, (e.g.) "LR AQM" (located on front of data logger, may have to hit {ESC} a couple of times before typing)
- Select: "L" Login
- Type password: **XXXXXXXXXX** (not case sensitive), this brings up Home Menu
- Select: "C" Configuration Menu <ENTER>
- Select: "C" Configure Calibrations <ENTER>

- Select: "S" Start a Calibration Program <ENTER>
- Select: "5%GCERT" <ENTER>

The 5% GCERT runs for 40 minutes, 15 minutes equilibration + 5 x 5 minute blocks.

- ESC, ESC, ESC to Home Menu
- Select: "D" Real-Time Display Menu <ENTER>
- Select: "C" Continuous Avg Report <ENTER>
- Start Continuous Report (for all five (5) channels) <ENTER>

```

ESC 8832 v3.00 ID:LR      Continuous Avg Report Setup      03/05/10 09:15:47
Average Interval          : 1m
Show Channels              : 146GFW,146AFW,AC50/100,AC10/20,ACKAVG

# of Flags to Report      : 02
Use Decimal Positioner?   : Y
Start Continuous Report

```

Monitor the 146GFW (146C gas flow averages) and AC50/100 (Alicat gas flow averages)

TIME	146GFW	146AFW	AC50/100	AC10/20	ACKAVG
03/05 12:30	2.46	0.0	2.46 <C	0.0	2.46 <R
03/05 12:31	2.46	0.0	2.46 <C	0.0	2.46 <R
03/05 12:32	2.46	0.0	2.46 <C	0.0	2.46 <R
03/05 12:33	2.46	0.0	2.46 <C	0.0	2.46 <R
03/05 12:34	2.46	0.0	2.46 <C	0.0	2.46 <R
03/05 12:35	2.46	0.0	2.46 <C	0.0	2.46 <R
03/05 12:36	2.46	0.0	2.46 <C	0.0	2.46 <R
03/05 12:37	2.46	0.0	2.46 <C	0.0	2.46 <R
03/05 12:38	2.46	0.0	2.46 <C	0.0	2.46 <R
03/05 12:39	2.46	0.0	2.46 <C	0.0	2.46 <R
03/05 12:40	2.46	0.0	2.46 <C	0.0	2.46 <R
03/05 12:41	2.46	0.0	2.46 <C	0.0	2.46 <R
03/05 12:42	2.46	0.0	2.46 <C	0.0	2.46 <R
03/05 12:43	2.46	0.0	2.46 <C	0.0	2.46 <R
03/05 12:44	2.46	0.0	2.46 <C	0.0	2.46 <R
03/05 12:45	2.46	0.0	2.46 <C	0.0	2.46 <R
03/05 12:46	2.46	0.0	2.46 <C	0.0	2.46 <R

ESC or SPACE to exit

The 5% GCERT status can also be monitored by:

- ESC, ESC, ESC to Home Menu
- Select: "S" Start a Calibration Program <ENTER>
- Select: "C" Continuous Avg Report <ENTER>

```

ESC 8832 v3.00  10:LR      Current Calibration Status      03/05/10 09:2
-----
Sequence  Type      Status
-----
100CCFC   Auto      Runs at 12/12/12 00:00:00
10LPMFC   Auto      Runs at 12/12/12 00:00:00
20%ACERT  User      INACTIVE
20%GCERT  User      INACTIVE
20LPMFC   Auto      Runs at 12/12/12 00:00:00
35%ACERT  User      INACTIVE
35%GCERT  User      INACTIVE
5%ACERT   User      INACTIVE
5%GCERT   User      5%GASK1 (19m 5s left) ←
50%ACERT  User      INACTIVE
50%GCERT  User      INACTIVE
50CCNFC   Auto      Runs at 12/12/12 00:00:00
65%ACERT  User      INACTIVE
65%GCERT  User      INACTIVE
80%ACERT  User      INACTIVE
80%GCERT  User      INACTIVE
95%ACERT  User      INACTIVE
95%GCERT  User      INACTIVE
--- ESC or SPACE to exit ---

```

When the 5%GCERT is finished, the "<C" appearing next to AC50/100 1 minute averages and the "<B" next to ACKAVG 1 minute averages will disappear.

TIME	146GFW	146AFW	AC50/100	AC10/20	ACKAVG
03/05 12:30	2.46	0.0	2.46 <C	0.0	2.46 <B
03/05 12:31	2.46	0.0	2.46 <C	0.0	2.46 <B
03/05 12:32	2.46	0.0	2.46 <C	0.0	2.46 <B
03/05 12:33	2.46	0.0	2.46 <C	0.0	2.46 <B
03/05 12:34	2.46	0.0	2.46 <C	0.0	2.46 <B
03/05 12:35	2.46	0.0	2.46 <C	0.0	2.46 <B
03/05 12:36	2.46	0.0	2.46 <C	0.0	2.46 <B
03/05 12:37	2.46	0.0	2.46 <C	0.0	2.46 <B
03/05 12:38	2.46	0.0	2.46 <C	0.0	2.46 <B
03/05 12:39	2.46	0.0	2.46 <C	0.0	2.46 <B
03/05 12:40	2.46	0.0	2.46 <C	0.0	2.46 <B
03/05 12:41	2.46	0.0	2.46 <C	0.0	2.46 <B
03/05 12:42	2.46	0.0	2.46 <C	0.0	2.46 <B
03/05 12:43	2.46	0.0	2.46 <C	0.0	2.46 <B
03/05 12:44	2.46	0.0	2.46 <C	0.0	2.46 <B
03/05 12:45	2.46	0.0	2.46 <C	0.0	2.46 <B
03/05 12:46	2.46	0.0	2.46	0.0	2.46

- After the "<B" disappears, enter **ACKAVG** flow into the 146C screen "**VOL FLOW CCM**" using the ← → and ↑ ↓ arrows, <ENTER>

```
GAS DRIVE 5%:
STD FLOW SCCM 00.500
VOL FLOW CCM 00.000
ENTER?
```

Gas Drive Screen

b. The 1 minute ACKAVG number is the average of 5, 5 minute consecutive blocks.

- ESC, ESC, ESC to Home Menu
- Select: "C" Configuration Menu <ENTER>
- Select: "C" Configure Calibrations <ENTER>
- Select: "K" Configure Math constants <ENTER>

```
ESC 8832 v3.00 ID:LR Set Math Pack Constants 03/05/10 10:20:55
Constant K1 = 2.47
Constant K2 = 2.47
Constant K3 = 2.46
Constant K4 = 2.47
Constant K5 = 2.46
Constant K6 = 1
Constant K7 = 1
Constant K8 = 1
Constant K9 = 1
```

Copy/paste or type the K1-K5 math constants into the 146C certification excel spreadsheet ("50 sccm Gas or 100 sccm Gas" tab).

Start at the 146C Main Menu, use the ↑ or ↓ pushbuttons to move the menu cursor ">" up or down, select **GAS FLOW CAL** <ENTER>, select **20% FS SCCM** <ENTER>

```
GAS AIR FLOW CAL:
5% FS SCCM 0.500
> 20% FS SCCM 2.000
35% FS SCCM 3.500
```

```
50% FS SCCM 5.000
65% FS SCCM 6.500
80% FS SCCM 8.000
95% FS SCCM 9.500
```

Gas Flow Calibration Menu

DO NOT PRESS "ENTER" —

```
GAS DRIVE 20%:
STD FLOW SCCM 02.000
VOL FLOW CCM 02.000
ENTER?
```

Gas Drive Screen

Start 20% GCERT

- ESC, ESC, ESC to Home Menu
- Select: "C" Configuration Menu <ENTER>
- Select: "C" Configure Calibrations <ENTER>
- Select: "S" Start a Calibration Program <ENTER>
- Select: "20%GCERT" <ENTER>

The 20% GCERT runs for 40 minutes (15 minutes equilibration + 5 x 5 minute blocks).

To check progress of 20% GCERT:

- ESC, ESC, ESC to Home Menu
- Select: "D" Real-Time Display Menu <ENTER>
- Select: "C" Continuous Avg Report <ENTER>
- Start Continuous Report (for all five (5) channels) <ENTER>

```

ESC 8832 v3.00 ID:LR      Continuous Avg Report Setup      03/05/10 09:15:47
Average Interval          : 1m
Show Channels              : 146GFW,146AFW,AC50/100,AC10/20,ACKAVG

# of Flags to Report      : 02
Use Decimal Positioner?   : Y
Start Continuous Report

```

Monitor the 146GFW (146C gas flow averages) and AC50/100 (Alicat gas flow averages)

TIME	146GFW	146AFW	AC50/100	AC10/20	ACKAVG
03/05 12:30	11.00	0.0	11.00<C	0.0	11.0<B
03/05 12:31	11.00	0.0	11.00<C	0.0	11.0<B
03/05 12:32	11.00	0.0	11.00<C	0.0	11.0<B
03/05 12:33	11.00	0.0	11.00<C	0.0	11.0<B
03/05 12:34	11.00	0.0	11.00<C	0.0	11.0<B
03/05 12:35	11.00	0.0	11.00<C	0.0	11.0<B
03/05 12:36	11.00	0.0	11.00<C	0.0	11.0<B
03/05 12:37	11.00	0.0	11.00<C	0.0	11.0<B
03/05 12:38	11.00	0.0	11.00<C	0.0	11.0<B
03/05 12:39	11.00	0.0	11.00<C	0.0	11.0<B
03/05 12:40	11.00	0.0	11.00<C	0.0	11.0<B
03/05 12:41	11.00	0.0	11.00<C	0.0	11.0<B
03/05 12:42	11.00	0.0	11.00<C	0.0	11.0<B
03/05 12:43	11.00	0.0	11.00<C	0.0	11.0<B
03/05 12:44	11.00	0.0	11.00<C	0.0	11.0<B
03/05 12:45	11.00	0.0	11.00<C	0.0	11.0<B
03/05 12:46	11.00	0.0	11.00<C	0.0	11.0<B

ESC or SPACE to exit

When the 20%GCERT is finished, the "<C" appearing next to AC50/100 1 minute averages and the "<B" next to ACKAVG 1 minute averages will disappear.

TIME	146GFW	146AFW	AC50/100	AC10/20	ACKAVG
03/05 12:30	11.00	0.0	11.00<C	0.0	11.0<B
03/05 12:31	11.00	0.0	11.00<C	0.0	11.0<B
03/05 12:32	11.00	0.0	11.00<C	0.0	11.0<B
03/05 12:33	11.00	0.0	11.00<C	0.0	11.0<B
03/05 12:34	11.00	0.0	11.00<C	0.0	11.0<B
03/05 12:35	11.00	0.0	11.00<C	0.0	11.0<B
03/05 12:36	11.00	0.0	11.00<C	0.0	11.0<B
03/05 12:37	11.00	0.0	11.00<C	0.0	11.0<B
03/05 12:38	11.00	0.0	11.00<C	0.0	11.0<B
03/05 12:39	11.00	0.0	11.00<C	0.0	11.0<B
03/05 12:40	11.00	0.0	11.00<C	0.0	11.0<B
03/05 12:41	11.00	0.0	11.00<C	0.0	11.0<B
03/05 12:42	11.00	0.0	11.00<C	0.0	11.0<B
03/05 12:43	11.00	0.0	11.00<C	0.0	11.0<B
03/05 12:44	11.00	0.0	11.00<C	0.0	11.0<B
03/05 12:45	11.00	0.0	11.00<C	0.0	11.0<B
03/05 12:46	11.00	0.0	11.00	0.0	11.0

ESC or SPACE to exit

- a. After the "<B" disappears, enter **ACKAVG** flow into the 146C screen "**VOL FLOW CCM**" using the ←→ and ↑↓ arrows, <ENTER>

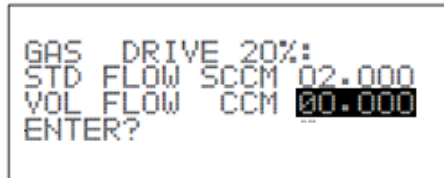

Gas Drive Screen

- b. The 1 minute ACKAVG number is the average of 5, 5 minute consecutive blocks.
- ESC, ESC, ESC to Home Menu
 - Select: "**C**" Configuration Menu <ENTER>
 - Select: "**C**" Configure Calibrations <ENTER>
 - Select: "**K**" Configure Math constants <ENTER>

```

ESC 8832 v3.00 ID:LR          Set Math Pack Constants          03/05/10 10:20:55
Constant K1 =                  11.00
Constant K2 =                  10.09
Constant K3 =                  10.09
Constant K4 =                  11.01
Constant K5 =                  11.01
Constant K6 =                   1
Constant K7 =                   1
Constant K8 =                   1
Constant K9 =                   1
Constant K10 =                  1
Constant K11 =                  1
Constant K12 =                  1
Constant K13 =                  1
Constant K14 =                  1
Constant K15 =                  1
Constant K16 =                  1_

ESC=Exit, CTRL-A=Alternate Values, CTRL-N=Next Page

```

Copy/paste or type the K1-K5 math constants into the 146C certification excel spreadsheet ("50 sccm Gas or 100 sccm Gas" tab). These constants are overwritten five (5) more times in the 146C certification.

Repeat steps for the remaining certification points.

2.3.4.9 146C Gas Verification

Once programmed, the verification is intended to run un-attended. Gas verification is two (2) hours long. The verification monitors the actual flow versus the flow settings for five points (5%, 25%, 50%, 75% and 95%) equally spaced flows along the range of the device. The $\Delta\%$ of 146GFW averages and AC50/100 averages should fall within:

	50 sccm	100 sccm	10 slpm	20 slpm
5%	$\leq (\pm) 6.00\%$	$\leq (\pm) 5.00\%$	$\leq (\pm) 4.00\%$	$\leq (\pm) 3.00\%$
25%	$\leq (\pm) 1.00\%$	$\leq (\pm) 1.00\%$	$\leq (\pm) 1.00\%$	$\leq (\pm) 1.00\%$
50%	$\leq (\pm) 1.00\%$	$\leq (\pm) 1.00\%$	$\leq (\pm) 1.00\%$	$\leq (\pm) 1.00\%$
75%	$\leq (\pm) 1.00\%$	$\leq (\pm) 1.00\%$	$\leq (\pm) 1.00\%$	$\leq (\pm) 1.00\%$
95%	$\leq (\pm) 1.00\%$	$\leq (\pm) 1.00\%$	$\leq (\pm) 1.00\%$	$\leq (\pm) 1.00\%$

sccm = standard cubic centimeters per minute

slpm = standard liters per minute

Disconnect the Alicat from the 146C calibrator, cap both ends and re-zero the Alicat.

Tare - Pushing the labeled "**Tare**" button for about 5 seconds in the upper right hand corner (Figure 1) tares the flow meter and provides it with a reference point for zero flow. **Note:** It is critical to have a stable tare before starting the air verification procedure. This is a simple but important step in obtaining accurate measurements.

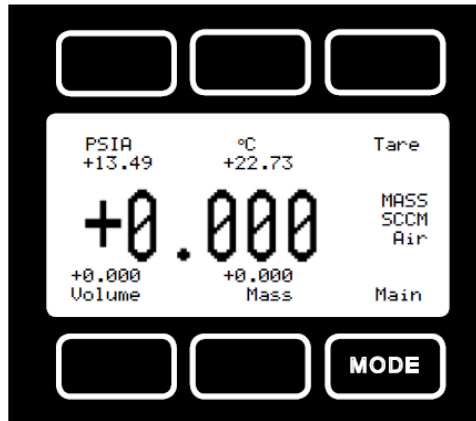

Figure 1 Alicat Mode Screen

- ESC, ESC, ESC to Home Menu
- Select: "**C**" Configuration Menu <ENTER>
- Select: "**C**" Configure Calibrations <ENTER>
- Select: "**S**" Start a Calibration Program <ENTER>
- Select: "**50CCMFC**" <ENTER>
- ESC, ESC, ESC to Home Menu
- Select: "**D**" Real-Time Display Menu <ENTER>
- Select: "**C**" Continuous Avg Report <ENTER>
- Start Continuous Report (for all five (5) channels) <ENTER>

```
ESC 8832 v3.00 ID:LR      Continuous Avg Report Setup      03/05/10 09:15:47
Average Interval          : 1m
Show Channels              : 146GFW,146AFW,AC50/100,AC10/20,ACKAVG

# of Flags to Report      : 02
Use Decimal Positioner?   : Y
Start Continuous Report
```

Monitor the channels while taring the Alicat.

TIME	146GFW	146AFW	AC50/100	AC10/20	ACKAVG
03/05 12:30	0.00	0.0	0.00	0.0	0.0
03/05 12:31	0.00	0.0	0.00	0.0	0.0
03/05 12:32	0.00	0.0	0.00	0.0	0.0
03/05 12:33	0.00	0.0	0.00	0.0	0.0
03/05 12:34	0.00	0.0	0.00	0.0	0.0
03/05 12:35	0.00	0.0	0.00	0.0	0.0
03/05 12:36	0.00	0.0	0.00	0.0	0.0
03/05 12:37	0.00	0.0	0.00	0.0	0.0
03/05 12:38	0.00	0.0	0.00	0.0	0.0
03/05 12:39	0.00	0.0	0.00	0.0	0.0
03/05 12:40	0.00	0.0	0.00	0.0	0.0
03/05 12:41	0.00	0.0	0.00	0.0	0.0
03/05 12:42	0.00	0.0	0.00	0.0	0.0
03/05 12:43	0.00	0.0	0.00	0.0	0.0
03/05 12:44	0.00	0.0	0.00	0.0	0.0
03/05 12:45	0.00	0.0	0.00	0.0	0.0

ESC or SPACE to exit

When the Alicat tare is stable, remove the caps and re-connect it to the 146C calibrator for verification.

146C must be in "**Remote**" mode:

To display the Mode screen, start at the **Main Menu** and select "**Mode**".

Using the Service Mode screen:

To change modes, use the ↑ or ↓ pushbuttons

To set the mode, press <ENTER>

```
MODE:          SERVICE
SET TO REMOTE?
```

Mode Screen

- ESC, ESC, ESC to Home Menu
- Select: "**C**" Configuration Menu <ENTER>
- Select: "**C**" Configure Calibrations <ENTER>
- Select: "**S**" Start a Calibration Program <ENTER>

- Select: "50CCMFC", when time clock reaches :03 press <ENTER>

```
ESC 8832 v3.00 ID:LR Choose List (Enter to Select) 03/05/10 09:18:03
100CCFC          95%ACERT
10LPMFC          95%GCERT
20%ACERT
20%GCERT
20LPMFC
35%ACERT
35%GCERT
5%ACERT
5%GCERT
50%ACERT
50%GCERT
50CCMFC
65%ACERT
65%GCERT
80%ACERT
```

K Factors 6-10 (146 Flow) with durations:

	Verification Point:
K6: 40 minutes, average last 5x1 minute averages	5%
K7: 20 minutes, average last 5x1 minute averages	25%
K8: 20 minutes, average last 5x1 minute averages	50%
K9: 20 minutes, average last 5x1 minute averages	75%
K10: 20 minutes, average last 5x1 minute averages	95%

K Factors 11-15 (Alicat Flow) with durations:

	Verification Point:
K11: 40 minutes, average last 5x1 minute averages	5%
K12: 20 minutes, average last 5x1 minute averages	25%
K13: 20 minutes, average last 5x1 minute averages	50%
K14: 20 minutes, average last 5x1 minute averages	75%
K15: 20 minutes, average last 5x1 minute averages	95%

To view verification results:

- ESC, ESC, ESC to Home Menu
- Select: "C" Configuration Menu <ENTER>
- Select: "C" Configure Calibrations <ENTER>
- Select: "K" Configure Math constants <ENTER>

ESC 8832 v3.00 ID:LR		Set Math Pack Constants		03/22/	
Constant K1	=	1			
Constant K2	=	1			
Constant K3	=	1			
Constant K4	=	1			
Constant K5	=	1			
Constant K6	=	2.47	} 146 GFW		
Constant K7	=	10.11			
Constant K8	=	25.11			
Constant K9	=	37.03			
Constant K10	=	47.03			
Constant K11	=	2.47	} AC 50/100		
Constant K12	=	10.11			
Constant K13	=	25.11			
Constant K14	=	37.04			
Constant K15	=	47.03			
Constant K16	=	1			

Copy/paste or type the K6-K15 math constants into the 146C certification excel spreadsheet ("Gas Verifications" tab).

2.3.4.10 Gas Data Collection

All minute averages and calibration data are automatically polled every 24 hours. This is done utilizing the E-DAS Autopoll feature. Any minute average or calibration report can be examined using the "Reports" tab on the E-DAS Ambient menu. Data is stored in C:\EDASSCR\146C verify and certify 02-25-10\.

To view gas data, open E-DAS Ambient menu. Click on "**Reports**" tab.

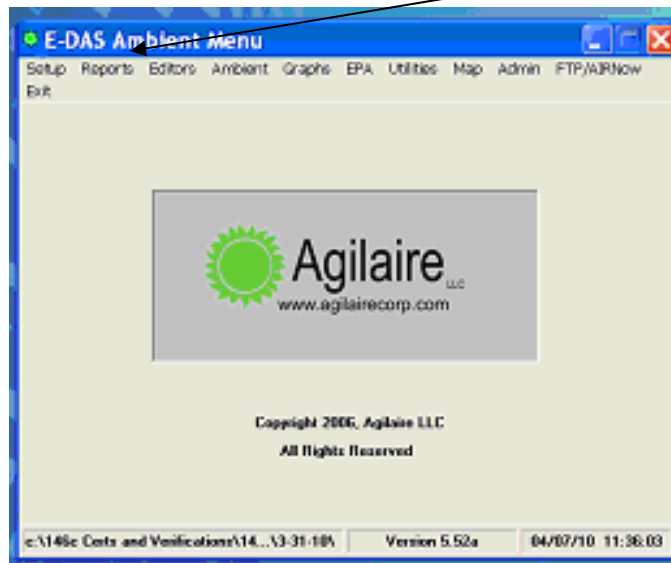

On drop down, select "**Calibration Report**".



Select the "**GCERT**" certification points and range of dates, click "**OK**".

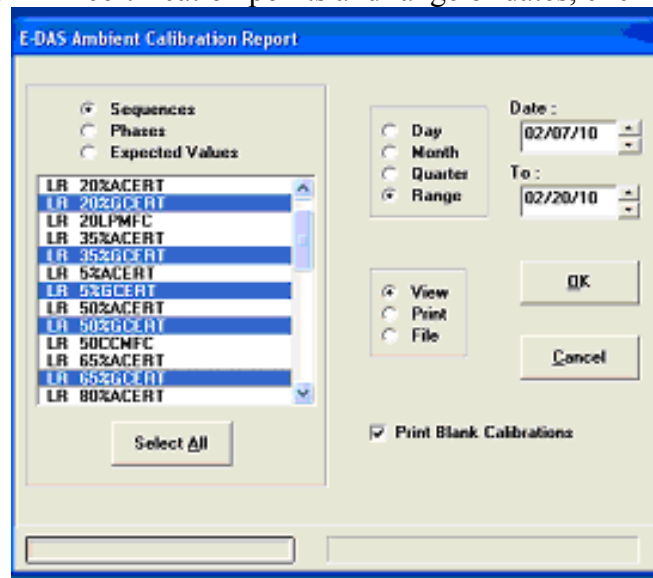

Date	Sequence Id	Sequence Name	Phase Name	Param Name	Start Time	End Time	Calibration Value	Expected Value	Drift (%Span)
03/09/10	LR	20%GCERT	20%GASK1	AC50/100	10:46	11:06	9.91	.00	
			20%GASK2	AC50/100	10:46	11:11	9.90	.00	
			20%GASK3	AC50/100	10:46	11:16	9.90	.00	
			20%GASK4	AC50/100	10:46	11:21	9.91	.00	
			20%GASK5	AC50/100	10:46	11:26	9.91	.00	
		35%GCERT	35%GASK1	AC50/100	11:46	12:06	17.45	.00	
			35%GASK2	AC50/100	11:46	12:11	17.46	.00	
			35%GASK3	AC50/100	11:46	12:16	17.48	.00	
			35%GASK4	AC50/100	11:46	12:21	17.45	.00	
			35%GASK5	AC50/100	11:46	12:26	17.45	.00	
		5%GCERT	5%GASK1	AC50/100	09:12	09:32	2.42	.00	
			5%GASK2	AC50/100	09:12	09:37	2.43	.00	
			5%GASK3	AC50/100	09:12	09:42	2.42	.00	
			5%GASK4	AC50/100	09:12	09:47	2.42	.00	
			5%GASK5	AC50/100	09:12	09:52	2.42	.00	

Gas Certification Points

To check gas verification, select the "20LPMFC" and range of dates, click "OK"

E-DAS Ambient Calibration Report

Sequences
 Phases
 Expected Values

Day
 Month
 Quarter
 Range

Date : 02/07/10
To : 02/20/10

View
 Print
 File

Print Blank Calibrations

OK
Cancel

Select All

Date	Id	Sequence Name	Phase Name	Param Name	Start Time	End Time	Calibration Value	Expected Value	Drift (%Span)
02/07/10	LR	20LPMFC	5%RUN20	146AFW	11:32	12:12	1001	1000	
				AC10/20	11:32	12:12	1002	1000	
			25%RN20	146AFW	11:32	12:33	5001	5000	
				AC10/20	11:32	12:33	5002	5000	
			50%RN20	146AFW	11:32	12:54	10001	10000	
				AC10/20	11:32	12:54	10002	10000	
			75%RN20	146AFW	11:32	13:16	15002	15000	
				AC10/20	11:32	13:16	15002	15000	
			95%RN20	146AFW	11:32	13:37	19002	19000	
				AC10/20	11:32	13:37	19002	19000	

Gas Verification Points

The calibrator will have a tag when certified/verified reading:

146C SN _____
Date Certified _____
Date Expires _____
Tech _____

2.3.4.11 146C Cleaning

Disconnect power, remove cover and blow out with nitrogen or compressed air. Check electrical connections on circuit boards, etc.

2.3.4.12 146C Routine Maintenance

Chapter 6 of the 146C instrument manual provides a troubleshooting guide for locating and correcting problems that can affect the normal operation of the Model 146C. This guide describes malfunctions, possible causes, and corrective actions.

Chapter 7 explains how to replace the Model 146C subassemblies. This section describes the step-by-step adjustment and replacement procedures for the Model 146C. This section assumes that the subassembly has been identified and needs service or replacement.

Note: Normal precautions should be used when working on the inside of the instrument with the power connected.

Solenoid Replacement

There are four (4) different solenoids used on the Model 146C. The following instructions cover all cases.

Equipment Required:

- Solenoid (For Part No. see 4, 5, 6, 7, 8 and 9 below)
- Open-end wrench - 5/8", 9/16"
- Nut driver - 1/4"

1. Disconnect power and remove cover.
2. Unplug defective solenoid from cable connecting to logic board.
3. Disconnect all teflon lines from defective solenoid.
4. Gas solenoid on rear panel (Part #8130).
 - a) Loosen and remove nut holding defective solenoid onto rear panel. Remove solenoid.
 - b) Remove fittings from solenoid.
 - c) Install fittings into new solenoid in same manner as they were removed.
 - d) Install new solenoid in reverse manner.
5. Zero air solenoid (Part #8130).
 - a) Loosen all fittings holding solenoid.
 - b) Remove four screws holding flowmeter bracket onto floor plate.
 - c) Move flowmeter bracket forward to loosen solenoid.
 - d) Remove solenoid.
 - e) Install new solenoid in reverse order.
6. Ozone solenoid (Part #8130).
 - a) Loosen and remove bracket holding ozone solenoid onto divider panel.
 - b) Remove ozonator assembly.
 - c) Remove ozonator solenoid from ozonator.
 - d) Install new solenoid in reverse order.
7. Bypass solenoid (Part #8119).
 - a) Remove flowmeter bracket.
 - b) Remove solenoid from flowmeter bracket.
 - c) Install new solenoid in reverse order.
8. Perm 1 solenoid (Part #7368)
 - a) Remove pressure regulator from divider panel by removing knurled plastic nut holding pressure regulator onto divider panel. Remove pressure regulator solenoid assembly.
 - b) Remove solenoid from pressure regulator.
 - c) Install new solenoid in reverse order.
9. Perm 2 solenoid (Part #8131)
 - a) Remove solenoid by loosening two (2) screws holding solenoid onto divider panel.
 - b) Install new solenoid in reverse order.
10. After replacement of any solenoid, leak check as described (page 4).

DC POWER SUPPLY BOARD REPLACEMENT

Equipment required:

Nut driver - 1/4"

Screw driver

DC power supply (Part No. 14291)

1. Wear an antistatic strap when working around the electronic components.
2. Turn instrument off, unplug the power cord, and remove the instrument cover.

3. Disconnect all plug-in connections from power supply board being replaced.
4. Remove screws holding board to chassis and remove board.
5. Install new board by following the above directions in reverse.
6. Re-install the instrument cover.

Ozonator Lamp Replacement

Equipment Required:

Replacement lamp (P/N #8645)
Allen wrench - 7/64"

1. Wear an antistatic strap when working around the electronic components.
2. Disconnect power and remove cover.
3. Unplug lamp from ozonator power supply.
4. Slide insulation off the lamp handle onto the lamp cord.
5. Loosen both Allen screws holding down lamp clamp.
6. Carefully slide lamp out of ozonator housing.
7. Slide insulation off of old lamp and slide onto new lamp.
8. Carefully slide new lamp into ozonator housing until it bottoms. Pull lamp out approximately 1/16" to allow for expansion when the lamp warms up, tighten Allen screw.
9. Position lamp so that the power input wires are oriented horizontally.
10. Check ozone production, which should be in excess of 2150 ppb. If ozone output is less than 2150 ppb, rotate lamp until specification is met.
11. Tighten Allen screws holding down lamp clamp.
12. Plug lamp into ozonator power supply, replace cover, and reconnect power.

Ozonator Heater Replacement

Equipment Required:

New heater (P/N #8593)
Allen wrench - 7/64"
Screwdriver
Heat conductive compound

1. Wear an antistatic strap when working around the electronic components.
2. Disconnect power and remove cover.
3. Unplug heater from ozonator power supply.
4. Remove top flange of ozonator housing.
5. Remove ozonator heater block from ozonator by removing four (4) Allen screws.
6. Coat new heater block with a thin film of heat conductive compound.
7. Install new ozonator heater block by following the above procedure in reverse.

Ozonator Power Supply Replacement

Equipment Required:

New ozonator power supply

Screw driver
Nut driver - 1/4"

1. Wear an antistatic strap when working around the electronic components.
2. Disconnect power and remove cover.
3. Unplug lamp, heater and cable to main power supply.
4. Remove seven (7) screws holding ozonator power supply board to bracket and remove board with a gently, but firm upwards pull.
5. Check that transformer is wired for proper voltage.
6. If regulators are being replaced make sure orientation is correct. Compare to PC board.
7. Install new ozonator power supply by following the above procedure in reverse. Care should be exercised to assure that the voltage regulators fit into the plugs or the board.

Temperature Control Permeation Oven PCB Replacement

Equipment required:

Nut driver - 1/4"
Replacement PCB (Part No. 8953)

1. Turn instrument off, unplug the power cord, and remove the instrument cover.
2. Disconnect all plug-in connections from permeation oven.
3. Remove four screws holding permeation oven PCB to oven assembly.
4. Install new permeation oven PCB assembly by following the above procedure in reverse.

Mass Flow Controller Replacement

Equipment Required:

Nut driver - 1/4", 5/16"
New mass flow controller for 10 LPM (P/N #8093)
New mass flow controller for 20 LPM (P/N #8094)
New mass flow controller for 50 SCCM (P/N #8095)
New mass flow controller for 100 SCCM (P/N #8096)

1. Disconnect power and remove cover.
2. Loosen all four (4) fittings to mass flow controllers and three (3) fittings from bypass solenoid.
3. Remove four (4) screws holding flow controller bracket to chassis.
4. Remove flow controller assembly.
5. Remove defective flow controller from bracket by removing the two (2) screws holding flow controller to bracket.
6. Install new flow controller by following the above directions in reverse.
7. Leak check system and recertify.

Mass Flow Controller Alignment

The 146C MFC's main problem of concern is zero drift. The MFC's zero can be checked and adjusted as needed.

A test for MFC span can also be performed and adjusted as needed.

The linearity or 50% adjustment should not be attempted by the ECB. This point should be accommodated by certification of the 146C. If not, replace the MFC or send out for repair.

To test AIR and GAS MFC alignment:

Reset 146C to "DEFAULT"

Start at the 146C Main Menu, use the ↑ or ↓ pushbuttons to move the menu cursor ">" up or down and select > **Load Default Params** <ENTER>

```
MAIN MENU:      10:00
>MODE
GAS A           GAS A
GAS B           GAS B
GAS C           GAS C

OZONATOR
PERMEATION OVEN
PROGRAM
ALARMS
INSTRUMENT CONTROLS
DIAGNOSTICS
```

Note: Items shown below are only available in Service mode.

```
LOAD DEFAULT PARAMS
FLOW CONTROL FSCALES
ENTER PRES AND TEMP
ZERO AIR FLOW CAL
GAS FLOW CAL SOL
GAS FLOW CAL
EXTERNAL SOLENOIDS
A/D FREQUENCY
SET TEST DISPLAY
```

Main Menu Screen

```
LOAD DEFAULT PARAMS?
ARE YOU SURE?
HONEST?
```

Load Default Parameters with prompts

146C must be in "**Remote**" mode:

To display the Mode screen, start at the 146C **Main Menu** and select "**Mode**".

Using the Service Mode screen:

To change modes, use the ↑ or ↓ pushbuttons

To set the mode, press <ENTER>

```
MODE:          SERVICE
SET TO REMOTE?
```

Gas set to "**OFF**"

Remove outlet fittings from both MFC's

Install ¼" or ⅛" tubing plug on each MFC outlet

Using a digital volt meter (DVM) set to VDC, measure DC voltage on circuit board connections **J9-AIR** (pin 3 (-) and pin 1 (+)) and **J10-GAS** (pin 3 (-) and pin 1 (+)), voltage should be between .000 and .025 VDC

Adjust R3 in older MFC's

Adjust R46 in newer MFC's

To test MFC Span setting:

Have zero already checked and adjusted if necessary

Reset 146C to "DEFAULT" (if **Load Default Params** was done before zero alignment test there is no need to repeat)

Start at the 146C Main Menu, use the ↑ or ↓ pushbuttons to move the menu cursor ">" up or down and select > **Load Default Params** <ENTER>

```
MAIN MENU:      10:00  
>MODE  
GAS A          GAS A  
GAS B          GAS B  
GAS C          GAS C
```

```
OZONATOR  
PERMEATION OVEN  
PROGRAM  
ALARMS  
INSTRUMENT CONTROLS  
DIAGNOSTICS
```

Note: Items shown below are only available in Service mode.

```
LOAD DEFAULT PARAMS  
FLOW CONTROL FSCALES  
ENTER PRES AND TEMP  
ZERO AIR FLOW CAL  
GAS FLOW CAL SOL  
GAS FLOW CAL  
EXTERNAL SOLENOIDS  
A/D FREQUENCY  
SET TEST DISPLAY
```

Main Menu Screen

```
LOAD DEFAULT PARAMS?  
ARE YOU SURE?  
HONEST?
```

Load Default Parameters with prompts

Have the outlet lines connected in the operating configuration to the MFC's and appropriate Alicat connected to "OUTPUT" port (see pg. 54, 146C Rear View).

Apply 95% drive to MFC under test,

Start at the 146C Main Menu, use the \uparrow or \downarrow pushbuttons to move the menu cursor ">" up or down, and select **GAS FLOW CAL** or **ZERO AIR FLOW CAL** <ENTER>, select **95% FS SCCM** or **SLM** <ENTER>

```
GAS AIR FLOW CAL:  
> 5% FS SCCM 0.500  
20% FS SCCM 2.000  
35% FS SCCM 3.500
```

```
50% FS SCCM 5.000  
65% FS SCCM 6.500  
80% FS SCCM 8.000  
95% FS SCCM 9.500
```

Gas Flow Calibration Menu

Using a digital volt meter (DVM) set to VDC, measure DC voltage on power supply circuit board connections **J9-AIR** (pin 3 (-) and pin 1 (+)) and **J10-GAS** (pin 3 (-) and pin 1 (+)), voltage should be ideally 4.750 VDC, but can be between 4.600 VDC and 4.900 VDC

Adjust 100% potentiometer R9 in older MFC's

Adjust 100% potentiometer R75 in new MFC's

146C Setup

146C Option Switch Settings (Diagnostics):

#1	I/O Remote	ON	#5	Spare	OFF
#2	Spare	OFF	#6	Spare	OFF
#3	Ozonator	ON	#7	NO of Gases	OFF
#4	Perm Oven	OFF	#8	NO of Gases	OFF

Instrument ID: 51 (Instrument Controls)

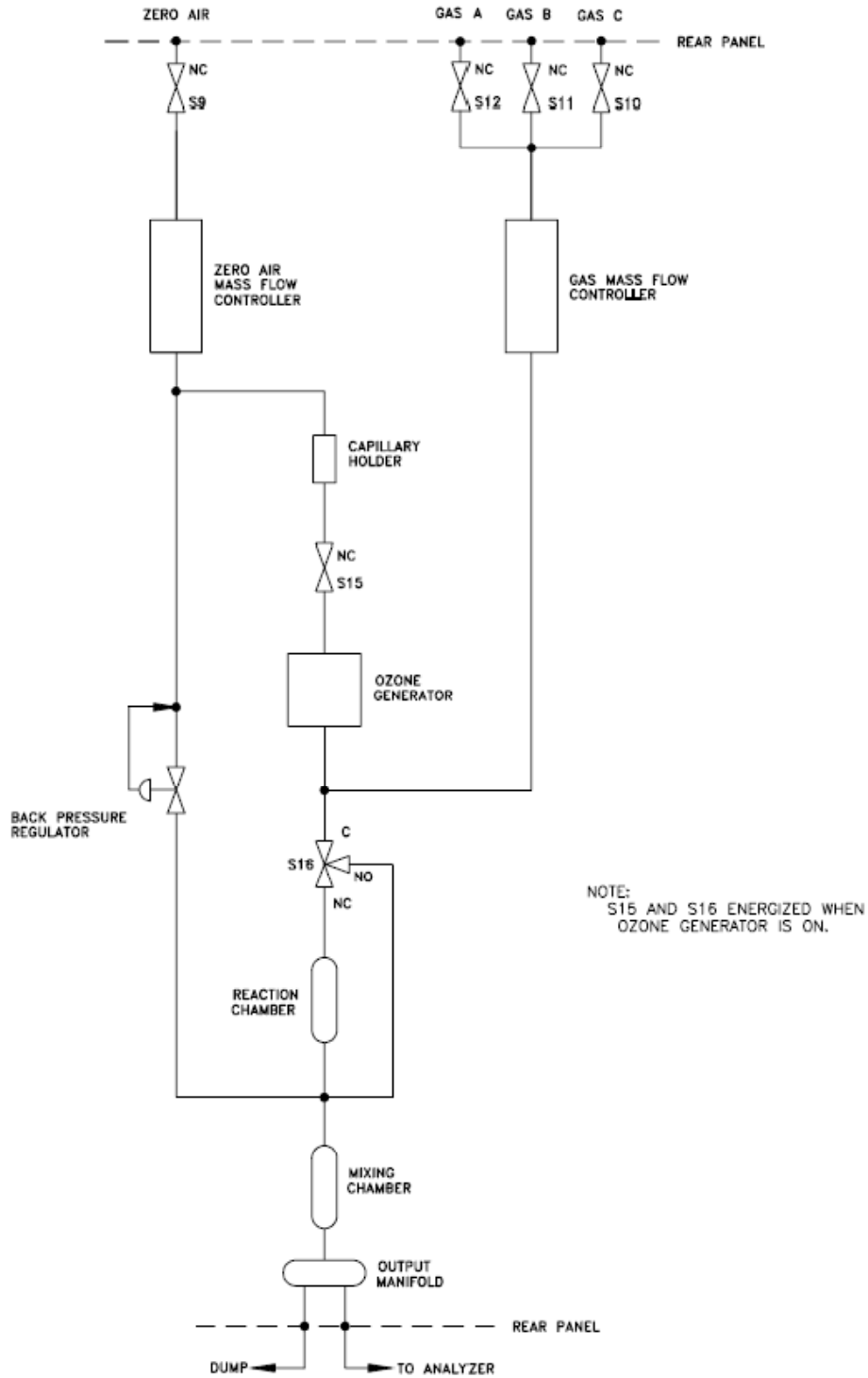

Figure 1 Model 146C Hardware Configuration, Standard Gas Dilution System



Figure 2 146C Front View

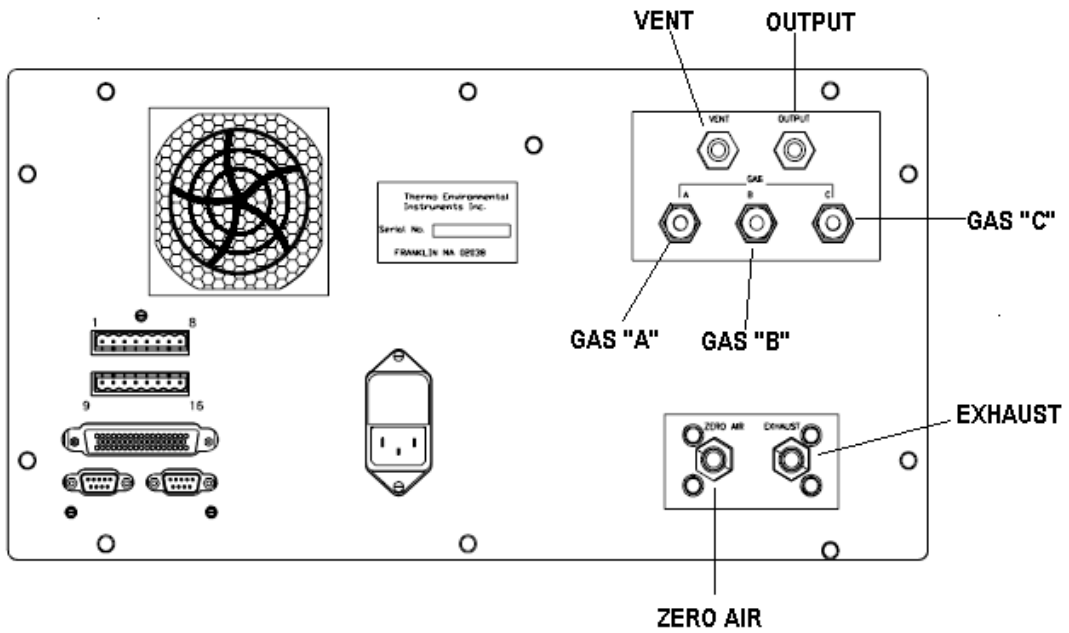

Figure 3 146C Rear View

Sign-Off Sheet

I certify that I have read, understand and agree to follow the contents of Revision 12.0 of the "Thermo Environmental 146C Calibrator Certification" QAP/SOP with an effective date of September 1, 2011. **Sign, date and return to the Ambient Monitoring Section Chief.**

ECB Technician: Mark Yaker

ECB Technician: ~~_____~~

ECB Technician: _____

ECB Technician: _____